

LECTURE NOTES
ON
ANALOG AND DIGITAL COMMUNICATION

5th Semester

Diploma in Electrical and Electronics Engineering



Prepared By:

Sumitra Behera

Department of Electrical and Electronics Engineering

Vedang Institute of Technology

Bhubaneswar, Khurda

Disclaimer

This document does not claim any originality and cannot be used as a substitute for prescribed textbooks. The information presented here is merely a collection by the committee members for their respective teaching assignments. Various sources of freely available materials from internet were consulted for preparing this document. The ownership of the information lies with the respective authors or institutions. Further, this document is not intended to be used for commercial purpose and the committee members are not accountable for any issues, legal or otherwise, arising out of use of this document. The committee members make no representations or warranties with respect to the accuracy or completeness of the contents of this document and specifically disclaim any implied warranties of merchantability or fitness for a particular purpose.

CONTENTS

S.No	Chapter Name	Page No
1	Elements of Communication System	1-12
2	Amplitude Modulation System	13-23
3	Angle Modulation	24-28
4	AM & FM Transmitter and Receiver	29-32
5	Analog to Digital Conversion & Pulse Modulation System	33-50
6	Digital Modulation Techniques	51-65

Unit 1

Elements of Communication System

Communication process- Concept of element of communication system and its block diagram.

What is Communication?

It is a process of sharing or exchange of information between two entities situated at a point. The two entities may be two persons, two machines or one person - one machine types. In communication the sharing of information occurs through the means such as words, actions, signs etc.

Need of Communication:

It helps people to share their ideas and feelings.

It also helps us to understand emotion and thoughts.

Process of Communication:

When it is required to share or exchange information between two entities one of the entities act as sender and another one as a receiver. The information initially remain in non-transferable form. The sender converts the non-transferable information into a transferable one. Then it sends or transmit the information towards the receiver through the interface which is known as a medium or channel. So a sender is otherwise called as a transmitter.

The medium or channel carries the information to the receiver. The receiver receives the information and converts that from transferable form to a non-transferable form. After that the receiver processes the information and converts that into usable form. It can also save the information for future use. From source to destination the moment of information occurs in different form of signals.

Block diagram of a communication system:

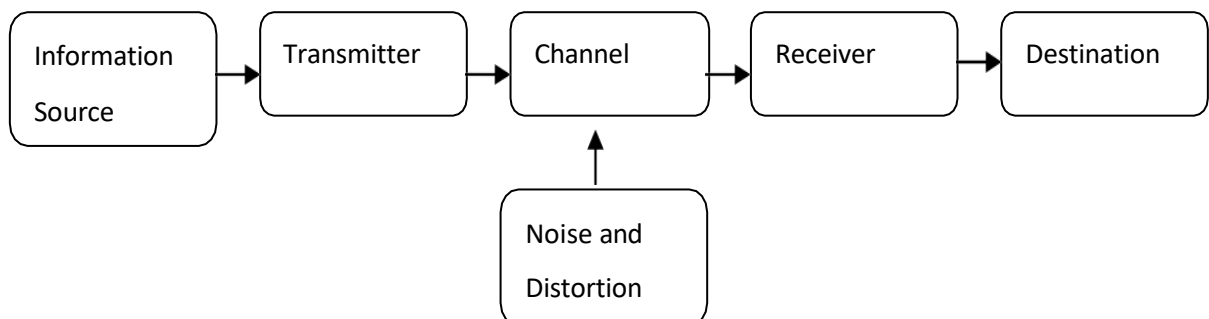

Elements of Communication System:

There are six elements of a general communication system those are:

Source of information

It provides the signal in its raw natural form. The source of information can be a natural type or manmade type. Initially the information can be of speech, music, and picture or of video type

Transmitter

It receive the information from source as its original form but the information in the form of sound, picture or data signal cannot be transmitted as it is. So it has to convert into a suitable electrical signal before transmitting through the medium or channel. As transmitter converts information from its original form into a transferable electrical form it is sometimes called as input transducer

Communication Channel or Medium

It is the interface between transmitter and receiver it carries the transmitted signal from transmitter to receiver. In general a communication channel is of physical type in which both the transmitter and receiver are connected with conducting wires, cables, optical fibres etc.

In conducting wires and cables the signal flows in the form of electrical signal. In optical fibre case, the signal flows in the form of ray of light. For long distance communication the channel is of wireless type which carries radio signal or electromagnetic signal through it.

Noise or interference

Noise is an unwanted signal which gets added with the transmitted signal while transmitting through the channel. Due to the addition of unwanted noise the quality of transmitted signal degrades. Sometimes signal may get lost within the channel. Noise can be treated as internal noise in case of wired medium or physical medium. For non-physical or wireless medium the noise is treated as external noise.

Receiver

It does the opposite process of transmitter. After receiving signal from communication channel it converts electrical signal back into the information signal. So sometimes the receiver is called as output receiver.

Destination

It helps in reproduction of signal or information in usable form or original form

It can also store the information for future use

Classification of Communication System

The classification of a communication system can be done according to the type of signal or type of channel or type of number of users seen.

Analogue and Digital Communication System

Depending on the operating signal a communication system can be treated as analogue or digital .In analog communication system, data or information is shared as an electrical or electronic signal of varying frequency and amplitude. Television broadcast and telephone transmission are most common example of analog communication system. On the other hand in a digital communication system the data or information is shared in the form of digital signal(i.e train of pulses). Most common example of digital communication system are internet, mobile communication, DTH etc.

Wired or Line Communication And Wireless or Space Communication

Depending upon the type of interface between transmitter and receiver a communication system can be treated as wired or wireless communication system. When the interface of channel is a physical link then a communication system is called as wired or line communication system

Common example of wired communication system are telephone networks, cable television, internet, fibre optic communication etc. Similarly, when the interface or channel is of non- physical type then a communication system is called as wireless or space communication system. Most common example of wireless communication system are radio broadcast, satellite communication, mobile communication, GPS etc.

One-Way, Two-Way and Multi-Way Communication System

Depending upon the type and number of users a communication system can be treated as one-way, two-way or multi-way communication system. If a communication system contains only two users and out of which if one user is permanently behaves as sender and other user permanently behaves as receiver then the system will be treated as one-way communication system.

Example: Television and Radio Communication

If a communication system contains only two users and both the users can behave as sender as well as receiver as per requirement then the system will be treated as two-way communication system

Example: Mobile Communication

If a communication system contains multiple number of users both in sender side as well as receiver side and all the users can behave as both sender as well as receiver as per the requirement then the system will be treated as multi-way communication system.

Example: Internet Conferencing, Video Conferencing

MODULATION:

Modulation means a change. In communication engineering modulation is a process of changing some characteristics of a carrier signal in accordance with the instantaneous value of a message signal. A carrier signal is a high frequency high powered periodic signal used to carry a low frequency low powered message signal to a far point. A message signal or modulating signal is a low frequency low powered signal which does not have the capability to propagate to a far point alone. Now during modulation some characteristics like phase, frequency, amplitude etc. of a carrier wave changes so as to generate a new signal which has the capability of movement or propagate to a larger distance. This newly generated signal is known as modulated signal which has the property that it can carry the information of message signal within it.

Need of Modulation

In modern communication most of the communication system needs to transmit a low frequency message signal to a large distance, very quickly, without any interference with utmost security. For this modulation plays an important role in designing of a system and achieving some requirements.

The following are the major points for which modulation is essential, those are

Practicality of Antenna

Reduction of Interference

Reduction of Noise

Multiplexing

Practicality of Antenna

Now a days when most of the communication systems are wireless type, antenna plays a major role in transmitting a signal. In wireless communication modulated signal transmitted through the wireless medium (i.e space) in the form of electromagnetic waves are radio waves. The function of antenna is to convert the electrical signal into electromagnetic signal at the transmitting end and vice versa at the receiving end. Now the shape of this transmitting antenna depends upon the frequency and wavelength of the operating signal. The length of the antenna is directly proportional to the wavelength and inversely proportional to the frequency of operating signal. The fundamental length of antenna is $\lambda/4$ (i.e. one fourth of wavelength). Now if we want to transmit a low frequency message signal alone then an antenna of very high length and size is required to design. Designing a large size of antenna is time consuming, difficult and costly. It is also difficult to install a large size of antenna at the top of a building or a tower. So if a message signal put into a process of modulation then frequency translation occurs and a high frequency modulated signal will result. Now to transmit a high frequency modulated signal the antenna required will be of low length and size.

Reduction of Interference

Interference is the process of mixing of two or more number of signals among themselves. In wireless communication when a signal propagates through open space, there is always a probability of interference with external signals. If a message signal which is generally comes under audio frequency range is transmitted through an open space then it can easily be attenuated when interfered by external signal. By modulation, frequency translation of audio frequency message signal occurs from low band to a high band so the modulated signal can not be easily interfered or affected by the external signals.

Reduction of Noise

Noise is the unwanted signal when intermix with the transmitted signal the power level of the transmitted signal gets attenuated. In open space communication the mixing of unwanted noise is maximum in probability so the probability of loss of transmitted signal is also high.

To avoid such probability the power level of the transmitted signal must be kept as high as possible. So incase of transmitting modulated signal in place of low frequency message signal the probability of loss of power can be minimise.

Multiplexing

It is a phenomenon of transmitting more than one number of signal simultaneously at a time. But if we transmit multiple message signal simultaneously without modulation then there will be the interference of all the Signals and any low frequency message signal may get lost. Now when a message signal is modulated with a carrier signal an envelope forms which secures the message within it. So if different message signals modulates with different carriers then they will attain different envelopes. After which if the signals will be transmitted simultaneously then there will be no interference.

Classification of Modulation

The process of modulation can be classified according to the type of message signal or modulating signal used along with the type of carrier signal used.

Tree of modulation:

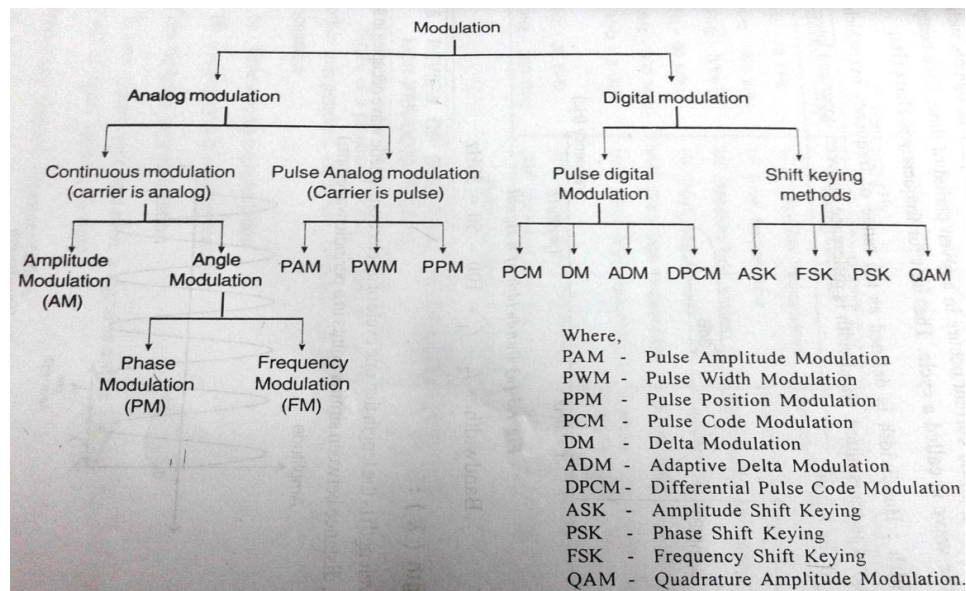

Modulation can be classified into Analogue Modulation and Digital Modulation in terms of message signal used. Similarly modulation can be classified into Analogue Modulation and Pulse Modulation in terms of the carrier signal used.

Analogue Modulation or Continuous Wave Modulation

It is the category of modulation in which both the message signal and carrier signal are analog in nature. Here message signal is analog in nature which changes some characteristics like amplitude, frequency and phase of an analogue carrier signal. Hence an analogue modulation can be classified into Amplitude Modulation, Frequency Modulation and Phase Modulation. The amplitude modulation is called as Linear Modulation. Whereas the frequency modulation and phase modulation combinely called as Angle Modulation.

Amplitude Modulation

It is the process in which the amplitude of a sinusoidal carrier signal changes in accordance with the instantaneous value of message signal on modulating signal.

Frequency Modulation

It is the process in which the frequency of sinusoidal carrier wave or carrier signal changes in accordance with the instantaneous value of a message or modulating signal.

Phase Modulation

It is the process in which the phase angle of sinusoidal carrier wave changes in accordance with the instantaneous value of a message or modulating signal.

Pulse Modulation or Pulse Wave Modulation

It is the category of modulation in which the message signal that used may be of analog type or Digital type but the carrier signal that used is always of digital type or train of pulses. When the message signal is of analog type along with digital type carrier signal then the pulse modulation is called as Analogue Pulse Modulation. Similarly when message signal is of digital type along with digital type carrier signal then the pulse modulation is called as Digital Pulse Modulation. Depending upon three characteristics of digital type or pulse type carrier signal the analogue pulse modulation is of three types those are:

Pulse Amplitude Modulation (PAM)

Pulse Width Modulation (PWM)

Pulse Position Modulation (PPM)

Pulse Amplitude Modulation (PAM)

It is the process in which the amplitude of rectangular pulses varies in accordance with the instantaneous value of sinusoidal signal or modulating signal.

Pulse Width Modulation (PWM)

It is the process in which the width of rectangular pulses varies in accordance with the instantaneous value of a sinusoidal message or modulating signal.

Pulse Position Modulation (PPM)

It is the process in which the position of the pulses or gap between the pulses varies in accordance with the instantaneous value of a sinusoidal message or modulating signal.

Pulse Code Modulation

It is the process in which a digital type carrier signal changes in accordance with a digital form or binary form of sinusoidal message signal or modulating signal.

Digital Modulation

It is the category of modulation in which the message signal is digital in nature where as a carrier signal is analogue in nature. Depending upon the change in amplitude, phase and frequency of analog carrier signal digital modulation is of three types, those are

Amplitude Shift Keying

Phase Shift Keying

Frequency Shift Keying

Amplitude Shift Keying

It is the process in which the amplitude of sinusoidal carrier wave changes in accordance with the digital message signal which is in the form of sequence of binary bits.

Phase Shift Keying

It is the process in which the phase of a sinusoidal carrier changes in accordance with the digital message signal which is in the form of a sequence of binary bits.

Frequency Shift Keying

It is the process in which the frequency of a sinusoidal carrier changes in accordance with the digital message signal which is in the form of a sequence of binary bits.

Signal

It is a function of one or more independent variables which contain some information. The independent variables may be time, temperature, position, pressure, distance etc. The most common independent variable is time.

Classification of Signal

Continuous Time and Discrete Time Signal

A signal is said to be continuous when it is defined for all instance of time it means a signal is having value continuously with respect to time.

Examples are: sine wave, cosine wave, current etc.

Similarly a signal is said to be discrete when it is defined at only discrete instant of time. It means a signal is having different values at different instant of time.

Examples are: All digital signals

Real and Complex Signal

A signal is said to be a real signal if its value is real number. Similarly a signal is said to be a complex signal if its value is a complex number.

Example of complex signals are:

Blood Velocity

Modulation in Telecommunication

Deterministic and Non-deterministic Signal

A signal is said to be deterministic if there is no uncertainty with respect to its value at any instant of time. It means for such type of signal, its value can be predicted at a specific time. Generally the pattern of such type of signal is regular in nature.

Examples are:

Sinusoidal Wave

Triangular Wave

Square Wave

Similarly a signal is said to be a non-deterministic if there is uncertainty with respect to its value at any instant of time. so its value cannot be predicted at a specific time. Generally the pattern of such type of signal is random in nature.

Examples are:

Thermal noise in electrical circuit

Lightning during rainy season

Periodic and Aperiodic Signal

A signal is said to be periodic if its occurrence repeats at a regular interval of time.so it is a repetitive signal. Mathematically it should satisfy the following condition

$$X(t) = X(t+T)$$

where t- time instant

T- time interval

Examples are

Sinusoidal Signal

Non-sinusoidal Signal

Similarly a signal is said to be an aperiodic if its occurrence does not repeat at a regular interval of time.So its occurrence is random in nature. It satisfy the relationship

$$X(t) \neq X(t+T)$$

Examples are:

Impulse Signal

Step Signal

Ramp Signal

Even and Odd signal

A signal is said to be an even signal if it is symmetrical in time domain. It also satisfy the following condition

$$X(t) = X(-t)$$

Examples:

Cosine Wave

Similarly a signal is said to be an odd signal if it is anti-symmetric in time domain so it satisfy the following condition

$$X(t) \neq X(-t)$$

Example

Sine Wave

Energy and Power signal

A signal is said to be an energy signal if it is having finite energy. Also for an energy signal the power is zero

Example

A signal which is having only one pulse

Similarly, a signal is said to be power signal if it is having finite power but for a power signal energy is always infinity.

Example

A sine wave of infinite length

Analogue and Digital Signal and Its conversion

Analog Signal

It is a signal whose value varies continuously with time. It means at a particular time instant an analog signal has a value. This value changes continuously in between two time instances.

Examples are:

- Temperature of atmosphere
- Pressure of atmosphere
- Speech

Digital Signal

It is a signal in which the value does not varies with respect to time. It means at a particular time instant if signal is present then at another time instant it may or may not present. It is basically represented by sequence of numbers.

Analog to Digital Conversion

In real world most of the data or information is present in analogue form. but to manipulate and process data for better understanding it is required to convert analog signal into digital form. Generally an analogue signal is a signal which is continuous in time domain and continuous in amplitude domain also. A digital signal is discrete in time domain and discrete in amplitude domain also. An analogue signal cannot directly been converted into a digital signal. Rather it first converted into an intermediate form in which signal remain continuous in amplitude but discrete in time domain. An analog signal is converted into an intermediate signal by the process of Sampling. After which the intermediate signal is converted into a digital signal by the process of Quantization.

Sampling

It is a process of conversion of continuous time signal into discrete time signal. It is a process to measure instantaneous values over a continuous time.

Quantization

It is a process of conversion of large amplitude level of a discrete time signal into small set of discrete levels. This discrete output amplitude levels are countable.

Bandwidth Limitation

Bandwidth limitation is the factor that characterizes the capacity of a transmitting channel to carry a certain range of frequency. Beyond the specific range if a signal having other frequency tries to pass through any channel then that gets blocked. So a bandwidth is the difference between the upper limiting frequency and the lower limiting frequency of a signal. The band of frequencies or bandwidth required for a particular transmission is called channel. The rate of data flow or channel capacity of a channel can be determined by the following formula

$$\text{Capacity, } C = B \log [1 + S/N]$$

Where, C- Channel Capacity

B- Bandwidth of a Channel

S- Signal Power associated with Channel

N- Noise Power associated with Channel

Unit 2

Amplitude Modulation system

The process of changing amplitude of carrier signal in accordance with the instantaneous values of message signal is called as amplitude modulation. In case of amplitude modulation both the message signal and carrier signal are sinusoidal in nature. Depending upon the instantaneous value of sinusoidal message signal the amplitude of the carrier signal varies and a new signal with new amplitude results this new signal is called as a Modulated Signal. The amplitude of carrier signal and modulated signal differs from each other whereas the frequency and phase of modulated signal remain same as that of the carrier signal

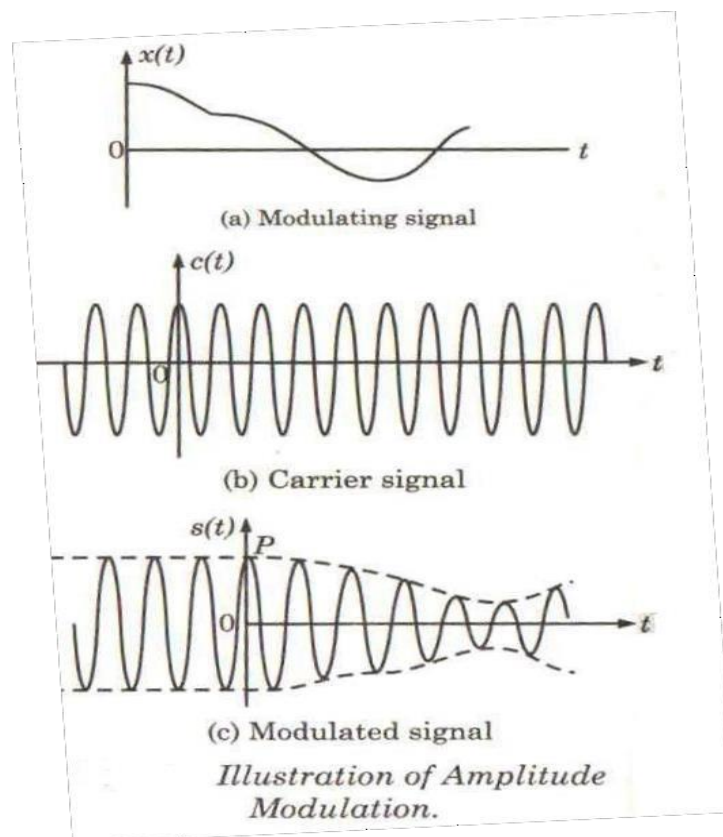

Since both message and carrier signal are sinusoidal they can be represented as

$$m(t) = A_m \cos \omega_m t$$

$$\text{and } c(t) = A_c \cos \omega_c t$$

With the principle of amplitude modulation the amplitude of carrier signal changes and a new amplitude results which can be determined as

$$A = A_c + m(t) \text{ ----- (eqn1)}$$

$$A = A_c + A_m \cos w_m t$$

$$A = A_c [1 + (A_m/A_c) \cos w_m t]$$

$$A = A_c [1 + Ma \cos w_m t]$$

Here $Ma = A_m/A_c$ known as Modulation Index or Modulation factor or Degree of Modulation.

Now the modulated signal $M(t)$ can be determined as

$$M(t) = A \cos w_c t$$

$$= A_c [1 + Ma \cos w_m t] \cos w_c t$$

$$= A_c \cos w_c t + A_c Ma \cos w_c t \cos w_m t$$

$$= A_c \cos w_c t + [A_c Ma/2] [\cos(w_c + w_m)t + \cos(w_c - w_m)t]$$

$$= A_c \cos w_c t + [A_c Ma/2] [\cos(w_c + w_m)t] + [A_c Ma/2] [\cos(w_c - w_m)t]$$

Frequency Spectrum of AM wave

It is a graph which shows the relations between the frequency and amplitude of modulated signal. From the expression of amplitude modulated signal it is clear that it contains three different frequency terms. Those are:

Carrier with frequency component w_c

Upper side band with frequency component $(w_c + w_m)$

Lower side band with frequency component $(w_c - w_m)$

Bandwidth of AM Wave

It is the range of frequency from lower side band to upper side band. It can be determined by subtracting lower cut off frequency from upper cut off frequency.

So Band Width

$$B = (w_c + w_m) - (w_c - w_m)$$

$$= w_c + w_m - w_c + w_m$$

$$= 2 w_m$$

So bandwidth of am signal is equal to twice of modulating frequency.

Modulation index or Modulation Factor

It is defined as the measure of extent of amplitude variation of carrier signal about its un modulated amplitude. We know the amplitude modulated signal and unmodulated amplitude of carrier signal are related with each other as follows

$$A_c[1+Ma \cos w_{mt}]$$

Now A- becomes a max for maximum value of $\cos w_{mt}$

and A becomes A_{min} for minimum value of $\cos w_{mt}$

Now for $[\cos w_{mt}]_{max} = 1$

$$A=A_{max} = A_c [1+Ma]$$

Similarly, $[\cos w_{mt}]_{min} = -1$

$$A=A_{min} = A_c [1-Ma]$$

$$\text{Now, } A_{max}/A_{min} = [A_c(1+Ma)]/[A_c(1-Ma)] = [1+Ma]/[1-Ma]$$

$$A_{max}-MaA_{min} = A_{min}+MaA_{min}$$

$$Ma A_{max}+ MaA_{min} = A_{max}-A_{min}$$

$$Ma[A_{max}+A_{min}] = A_{max}-A_{min}$$

$$Ma = [A_{max}-A_{min}]/[A_{max}+A_{min}]$$

Now, from eqⁿ 1

$$A = A_c + m(t) = A_c + A_m \cos w_{mt}$$

for maximum value, $\cos w_{mt} = 1$

$$\text{Then, } A=A_{max} = A_c+A_m$$

Similarly, for minimum value, $\cos w_{mt} = -1$

$$\text{Then } A=A_{min} = A_c-A_m$$

Now eqⁿ 1 can be rewritten as

$$Ma = [A_{max}-A_{min}]/[A_{max}+A_{min}] = [(A_c+A_m)-(A_c-A_m)]/[(A_c+A_m)+(A_c-A_m)]$$

$$Ma = 2A_m/2A_c$$

$$Ma = A_m/A_c$$

so for AM, modulation index is the ratio of amplitude of message signal to that of carrier signal.

Generation of Amplitude Modulated Signal

The electronic circuit which is used to generate an amplitude modulated signal is called as an Amplitude Modulator. The modulator circuit is designed to operate in two methods those are

Low Level AM Generation

High Level AM Generation

Low Level AM Generation

In this method of FM generation the modulator circuit is used to operate in a low power domain. The low-level AM generation method are basically seen in amateur radio transceivers which are basically used for non-commercial purposes. The various use of amateur radio transceivers are wireless experimentation, self-training, private recreation, contesting and emergency communication etc. In low level am generation the modulation of AM signal carried out at the beginning part of the transmitter. The modulation is carried out at low power level so during modulation the message signal and carrier signal are applied to the modulator circuit without amplification. So we cannot see any amplifier circuit before the modulated stage. The transmitter only have the amplifier circuit towards the final stage or towards the end.

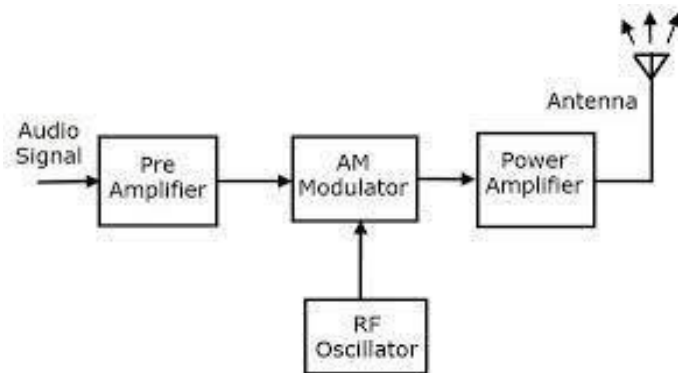

High Level AM Generation

In this method of AM generation, the modulation circuit is used to operate in a high power level or domain. The high-level AM generation methods are basically seen in high level AM transmitters, which are basically used for commercial AM broadcast. In high level AM generation the modulation of AM signal carried out towards the last stage of radio transmitters. As signal modulation is carried out at high power level the message signal and carrier signal are applied to the modulation circuit after amplification. So power amplifier circuits are seen before the modulation stage.

Block Diagram of High level AM Transmitters

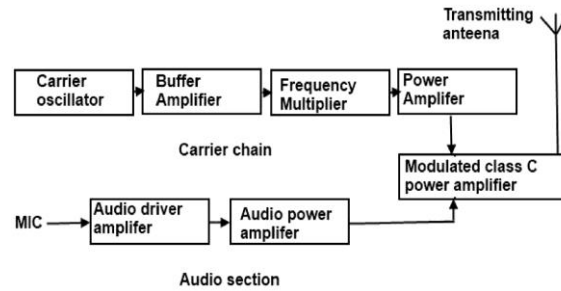

Figure (a) Block diagram of high level AM transmitter

Demodulation of AM waves

Demodulation is a process of extracting a message signal out of a modulated signal. A modulated signal generally contains both the message signal as well as carrier signal. The demodulator circuit separates out a carrier signal out of a modulated signal and leaves behind the message signal. The am demodulator circuit is of two types those are

Linear the Detector (envelope detector)

Square Law Detector

Linear detector is used to demodulate a high-level AM signal where as a Square Law demodulator is used to demodulate a low level AM signal.

Linear the Detector (envelope detector)

A linear diode detector is popularly used in commercial radio receivers. As it is used to demodulate at a high level AM signal, the diode used in the demodulator circuit operates over the linear region of its V-I characteristics. The linear diode detector circuit is simple and inexpensive in nature.

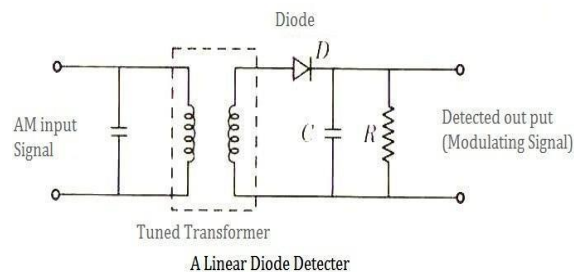

Here the high level AM signal is applied at the input circuit of a tuned transformer which is then induced in the secondary circuit of the transformer and appears at the input of diode D. As the voltage of input AM signal is more than 1 volt, the diode D operates in the linear region of its V-I characteristics. During the positive half of the input AM signal diode D behaves as forward bias and allows the current to pass through it. Hence the capacitor charges to the peak value of input. During the negative half cycle of input AM signal diode behaves as a reverse bias and does not allows any current to pass through it. Hence the capacitor does not charges but discharges through the load

resistor R_L . This discharge current of capacitor develops the output voltage across the register R_L . In this way the output voltage almost traces the envelope of the input AM signal which is nothing but the original message signal.

V-I characteristics:

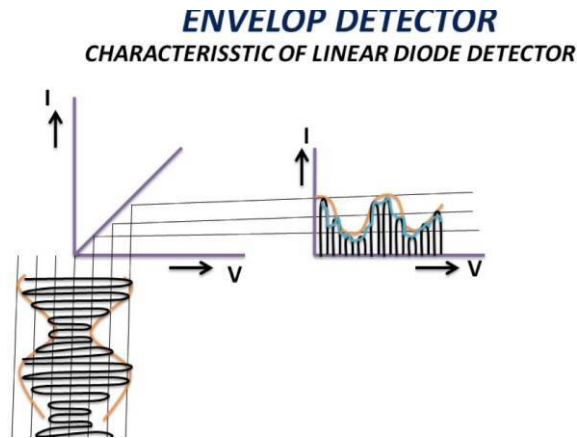

Square Law detector

A square-law detector is used to detect a message signal from a low level AM signal. The circuit is said to be a Square-Law detector circuit because the output of the circuit is proportional to the square of the input. It is because the diode present in the circuit operates within the non-linear region of its V-I characteristics. The circuit diagram is as follows

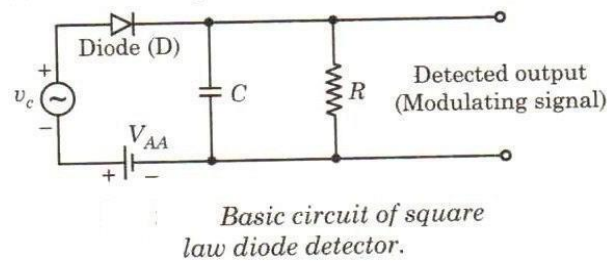

The DC voltage V_{AA} present in the circuit always keeps the diode in forward bias (i.e. during negative half of input AM signal also the diode D operates in forward bias). Now the input voltage that appears at the diode is the net voltage of V_c and V_{AA} .

Let V be the voltage of AM signal which can be denoted as

$$V = A(1 + M_a \cos w_m t) \cos w_c t$$

Let ' I ' be the diode current that flows through the load register that provides the overall output. Now according to Square Law principle ' I ' be proportional to the square of the input voltage V .

$$\text{Now } I = aV + bV^2$$

By substituting the value of $V = A(1 + M_a \cos w_m t) \cos w_c t$ we get

$$I = a[A \cos w_c t + A m \cos w_m t \cos w_c t] + b[A \cos w_c t + A m \cos w_m t \cos w_c t]^2$$

If the above equation is expanded then we may observe the terms having frequency components like $2w_c$, $2(w_c+w_m)$, $2(w_c-w_m)$, w_m , $2w_m$ etc. Now by passing the current through a low pass filter we can able to separate the term having frequency component w_m only.

V-I Characteristics

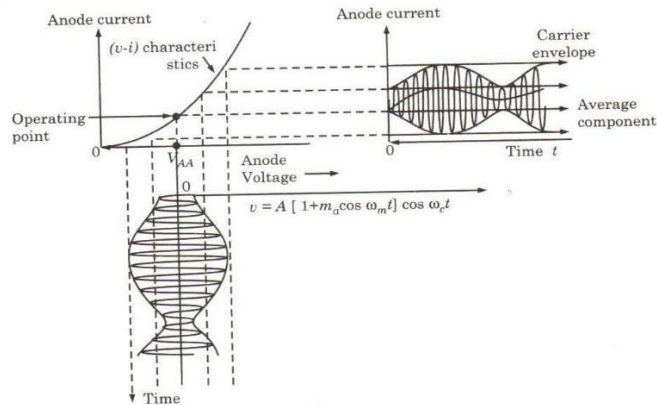

Double sideband suppressed carrier and single sideband signal:

We know the expression of a double sideband full carrier (DSB-FC) signal can be represented as

$$M(t) = A_c [1 + m(t)] \cos w_c t$$

$$= A_c \cos w_c t + m(t) A_c \cos w_c t$$

By suppressing the carrier portion we can convert a double sideband full carrier (DSB-FC) signal into a double sideband suppressed carrier (DSB-SC) signal. So the double sideband suppressed carrier signal can be represented as

$$M(t) = m(t) A_c \cos w_c t$$

This double sideband suppressed carrier (DSB-SC) signal can be obtained by multiplying message signal $m(t)$ with the carrier signal $\cos w_c t$ with the help of a product modulator.

In the DSB-SC signal the two sidebands are there namely upper side band (USB) and lower sideband (LSB). These two side bands (USB and LSB) are of mirror image of each other. Now to transmit the information only one side band is necessary. So a signal having only one side band without having the carrier component and other side band is called as a single sideband (SSB) signal.

Properties of DSB-SC Signal

A 180 degree phase reversal is seen in carrier when the message $m(t)$ goes negative from positive.

$$(\text{Bandwidth})_{\text{DSB-SC}} = 2 (\text{Bandwidth})_{\text{message}}$$

Modulated signal $M(t)$ is centred at carrier frequency with two side bands on both sides.

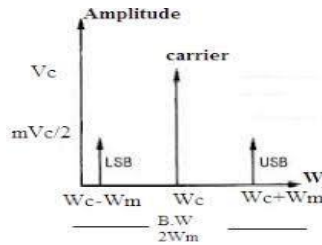

$$\begin{aligned} \text{Bandwidth, } B &= (w_c + w_m) - (w_c - w_m) \\ &= w_c + w_m - w_c + w_m \\ &= 2 w_m \end{aligned}$$

Generation of AM Signal

Practically generation of AM signal means the generation of double sideband suppressed carrier (DSB-SC) type AM signal. Because DSB-FC type AM signal is not used in day to day life. It is only taken as a standard for radio broadcasting. We know DSB-SC signal is generated by a product modulator. Now there are two types of product modulator that can generate DSB-SC signal. Those are

Balanced Modulator

Ring Modulator

Balanced Modulator

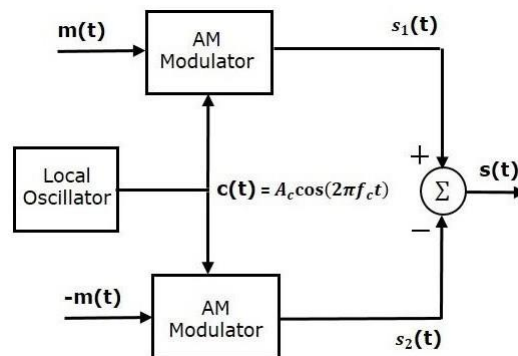

A balanced modulator consists of two identical AM modulators. In order to suppress the carrier signal these two AM modulators are connected in balanced condition. The AM modulators get carrier signal from a common local oscillator. But the message signal $m(t)$ is applied to the two modulators separately. In one AM modulator message is applied directly whereas in other it is applied with the phase reversal. Now the output of two AM modulators are of DSB-FC type. But when they mix with each other with the help of an adder a DSB-SC type signal results.

Now the output of AM1 can be represented as

$$S_1(t) = A_c[1+m(t)] \cos \omega_c t$$

Similarly the output of AM2 can be represented as

$$S_2(t) = A_c[1-m(t)] \cos \omega_c t$$

So when $S_1(t)$ and $S_2(t)$ are added with each other then a DSB-SC signal $S(t)$ results, which can be determined as

$$\begin{aligned} S(t) &= S_1(t) - S_2(t) \\ &= A_c[1+m(t)] \cos \omega_c t - A_c[1-m(t)] \cos \omega_c t \\ &= 2 m(t) A_c \cos \omega_c t \end{aligned}$$

Ring Modulator

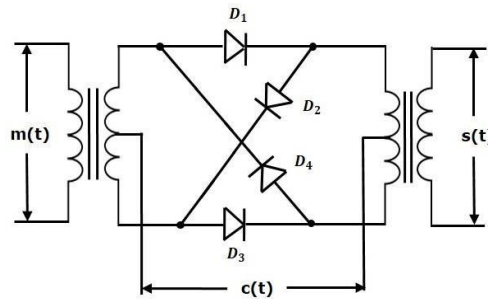

The above is a circuit of ring modulator where four identical diodes D_1 , D_2 , D_3 and D_4 are connected in between the secondary of Transformer T_1 and primary of a transformer T_2 . The four diodes are connected as a ring manner. The transformer T_1 is audio frequency type transformer. The transformer T_2 is a radio frequency type transformer. A square wave carrier generator is connected in between the two centre tap point of two transformers T_1 and T_2 .

Working

During positive half of the carrier the outer diodes D_1 and D_3 moves to forward bias and the message signal will be multiplied by +1. During negative half of the carrier the inner diodes D_2 and D_4 moves to forward bias and the message signal will be multiplied by -1. In each half cycle of carrier equal amount of current flows through the upper winding and lower winding of primary of a transformer T_2 . But this current flows opposite to each other.

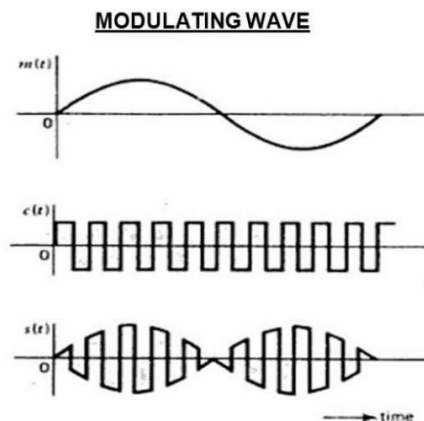

Demodulation of DSB-SC Signal

Synchronous Detection Method: (Coherent Detection Method)

It is a method in which received modulated DSB-SC signal is made to multiply with a locally generated carrier signal. This method is called as synchronous detection because the frequency of locally generated carrier signal is in synchronous with the frequency of the received DSB-SC signal. When the received DSB-SC signal is multiplied with locally generated carrier signal the resultant signal that produce will have two frequency components those are w_m and $2w_m$. When these two frequency components passes through a low pass filter only w_m frequency component reflects at the output. This frequency component is nothing but the necessary message signal.

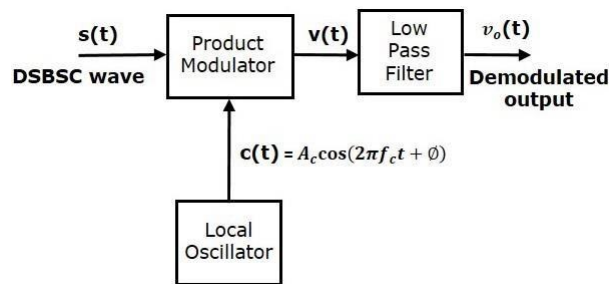

Here the multiplier produce the output $v(t)$ which can be determined as

$$\begin{aligned}
 V(t) &= [m(t)\cos w_c t] \cos w_c t \\
 &= m(t) \cos^2 w_c t \\
 &= \frac{1}{2} [m(t) \{1 + \cos 2 w_c t\}] \\
 &= m(t)/2 + \{m(t) \cos 2 w_c t\}/2
 \end{aligned}$$

When $V(t)$ pass through the low pass filter it produces the message $m(t)$.

Generation of SSB signal

As discussed earlier when the modulation process provides a single sideband with suppressed carrier, it is known as a single sideband suppressed carrier system (SSB-SC). In this type of modulation the modulated signal that produce consumes less bandwidth. The bandwidth of SSB signal is half of that of a DSB-SC signal which allows more number of signals to be transmitted in a particular frequency range. Reduction in bandwidth of a signal also reduces the probability of interference of noise. The SSB-SC type of signal transmission is seen in mobile communication, telemetry, military communication, amateur radio etc.

Filter Method of SSB Generation: (Indirect Method)

Such method is called as an indirect method because the SSB-SC signal is generated after generating a DSB-SC signal. Firstly a DSB-SC signal is generated by using a simple product modulator. This output of product modulator

contains two sidebands. When the output of product modulator passes through a bandpass filter a SSB-SC signal result.

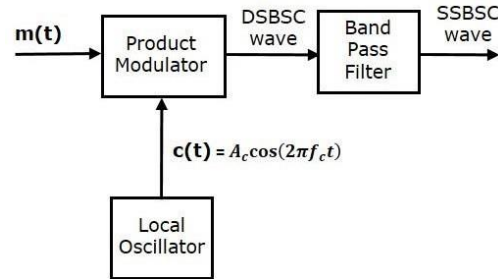

Now design of a band pass filter with sharp cut off frequency is quite critical. So practically a multiple stage filter method is used where multiple number of band pass filter are used.

Bandwidth of SSB SC Signal

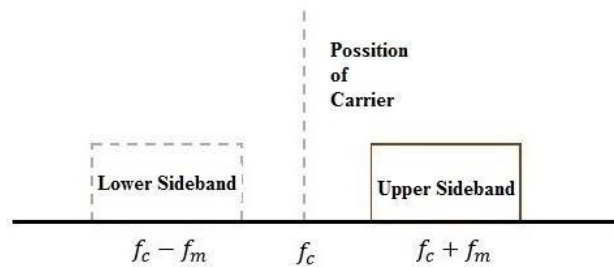

Vestigial Sideband Signal

As we discuss designing a band pass filter is difficult in SSB-SC signal generation because it is difficult to have a sharp cutoff frequency. If we could not able to design a filter with sharp cutoff frequency then there will be a probability that we may lose some information. So to overcome this probability a band shaping filter is used in place of a band pass filter whose function is to transmit a single sideband completely along with some narrow portion of other side band. This narrow portion of other side band is called as 'Vestige'. Such type of communication is called as Vestigial Sideband Communication. Generally VSB transmission is used for TV broadcasting.

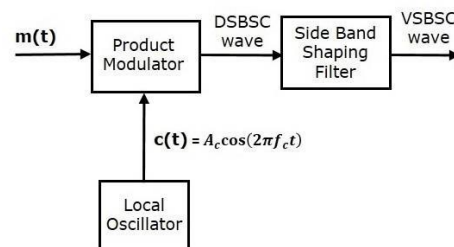

Unit-3

Angle Modulation

The modulation in which, the angle of the carrier wave is varied according to the baseband signal. An important feature of this modulation is that it can provide better discrimination against noise and interference than amplitude modulation. *Frequency Modulation (FM)* and *Phase Modulation (PM)* are the special cases of Angle modulation.

Phase modulation

In case of phase modulation the modulated signal can be represented by $s(t) = A_c \cos[\omega_c t + \Phi(t)]$

The angle $(\omega_c t + \Phi(t))$ undergoes a modulation around the angle $\theta = \omega_c t$. The signal is therefore an angular-velocity modulated signal. When the phase is directly proportional to the modulating signal, i.e., $\Phi(t) = n_p m(t)$, we call it phase modulation, where n_p is the

phase modulation index.

The instantaneous frequency of a phase modulated signal is given by $f_i(t)$

$$= f_c \cos(\omega_c t + k' m(t)), \text{ where } k' \text{ is a constant}$$

Waveform of PM signal:

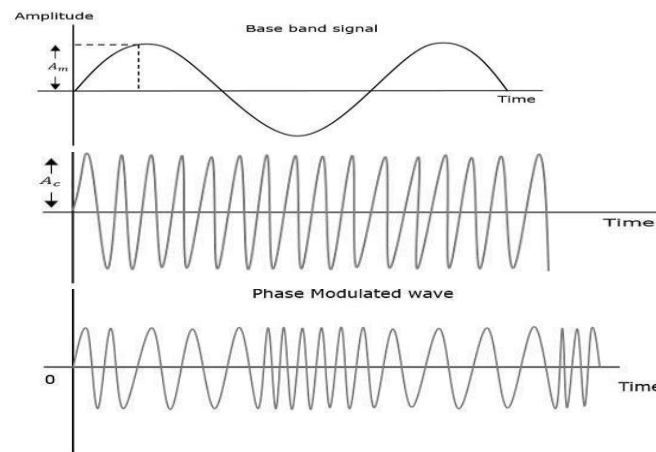

Frequency modulation

In case of frequency modulation, the modulating signal $e_m(t)$ is used to vary the carrier frequency. The change in frequency is proportional to the modulating voltage $k e_m(t)$, where k is a constant known as frequency deviation constant, expressed in Hz/V. The instantaneous frequency of the modulated signal can be represented by $f_i(t) = f_c + k e_m(t)$, where f_c is the carrier frequency.

For sinusoidal modulation

$$e_m(t) = E_m \cos 2\pi f_m t \quad \text{and} \quad f_i(t) = f_c + k e_m(t)$$

$$= f_c + k E_m \cos 2\pi f_m t = f_c + \Delta f \cos 2\pi f_m t$$

Therefore,

$$s(t) = E_c \cos \theta(t) \quad t$$

$$= E_c \cos (2\pi f_c t + 2\pi \Delta f \int_0^t \cos 2\pi f_m t \, dt)$$

$$= E_c \cos (2\pi f_c t + (\Delta f / f_m) \sin 2\pi f_m t)$$

The modulation index, denoted by β , is given by $\beta = (\Delta f / f_m)$ or $s(t) = E_c \cos (2\pi f_c t + \beta \sin 2\pi f_m t)$

Waveform of FM signal:

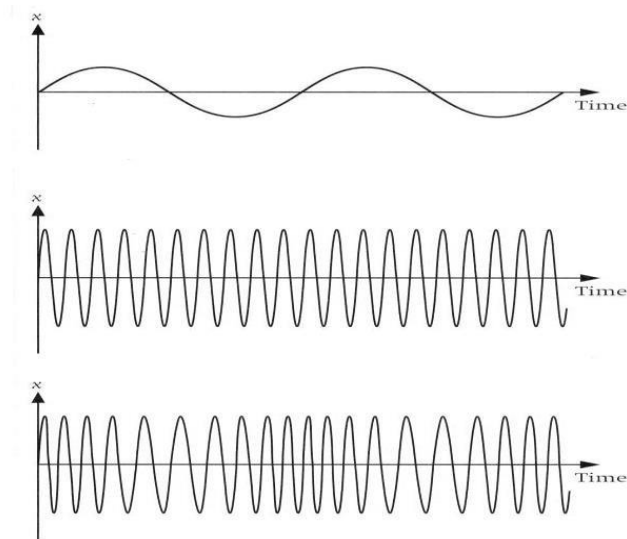

Bandwidth: The modulated signal will contain frequency components $f_c + f_m$, $f_c + 2f_m$, and so on. It can be best approximated based on Carson's Rule, when β is small.

$$B_T = 2(\beta + 1)B_m,$$

$$\text{where } \beta = \Delta f / B = n_f A_m / 2\pi B \text{ Or } B_T = 2\Delta f + 2B.$$

$$\text{Peak deviation} = \Delta f = (1/2\pi) n_f A_m \text{ Hz,}$$

where A_m is the maximum value of $m(t)$

It may be noted that FM requires greater bandwidth than AM. In figure below the bandwidth is shown to be 10 times that of the base band signal.

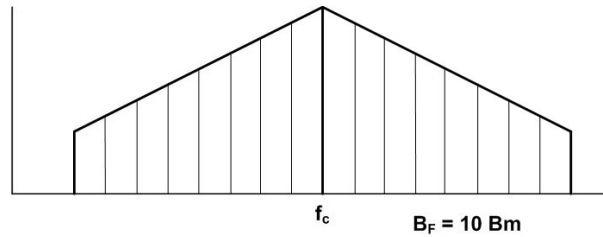

Figure: Bandwidth of a frequency modulated signal

Relationship between FM and PM

The relationship between the two types of angle modulated signal depicted in the figure below.

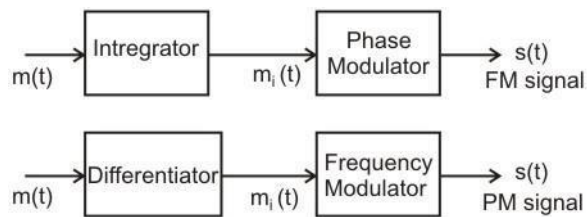

Figure : Difference between frequency and phase modulation

Let $m(t)$ be derived as an integral of the modulated signal $e_m(t)$, so that $m(t) = k \int e(t) dt$. Then with $k = k'k''$, we get $s(t) = E_c \cos(\omega_c t + k \int e(t) dt)$. The instantaneous angular frequency of $s(t)$ is $2\pi f_i(t) = d/dt [2\pi f_c t + k \int e(t) dt]$

$$\text{or } f_i(t) = f_c + (1/2\pi)k e(t)$$

The waveform is therefore modulated in frequency

In summary, these two together are referred to as angle modulation and modulated signals have similar characteristics. In this process, since the frequency or phase of the carrier wave is being modulated by the signal and the modulation lies near the base band, the external noise or electromagnetic interference cannot affect much the modulated signal at the receiving end. Analog data to Analog signal modulation techniques at a glance are shown in the following figure.

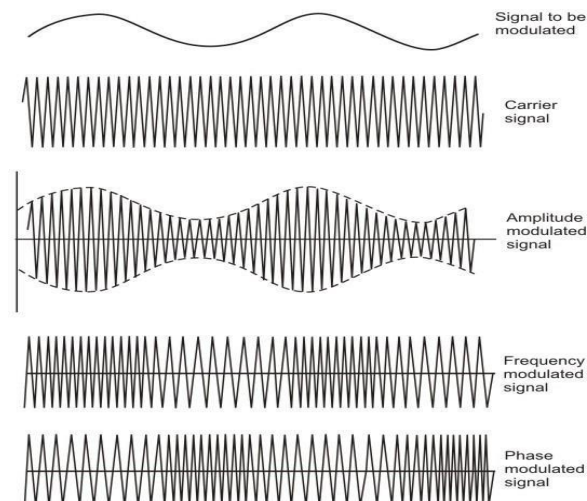

GENERATION OF FM WAVES:

FM waves are normally generated by two methods: indirect method and direct method

Indirect Method (Armstrong Method) of FM Generation:

Indirect Method (Armstrong Method) of FM Generation

In this method, narrow-band FM wave is generated first by using phase modulator and then the wideband FM with desired frequency deviation is obtained by using frequency multipliers

$$s(t) = A_c \cos \left[2\pi f_c t + 2\pi k_f \int_0^t m(t) dt \right]$$

$$\text{or, } s(t) = A_c \cos[2\pi f_c t + \phi(t)]$$

$$\phi(t) = 2\pi k_f \int_0^t m(t) dt$$

$$s(t) = A_c \cos(2\pi f_c t) \cos[\phi(t)] - A_c \sin(2\pi f_c t) \sin[\phi(t)]$$

The above eq is the expression for narrow band FM wave

In this case $\cos[\phi(t)] \approx 1$ and $\sin[\phi(t)] \approx \phi(t)$

$$s(t) = A_c \cos(2\pi f_c t) - A_c \sin(2\pi f_c t) \phi(t)$$

$$\text{or, } s(t) = A_c \cos(2\pi f_c t) - 2\pi A_c k_f \sin(2\pi f_c t) \int_0^t m(t) dt$$

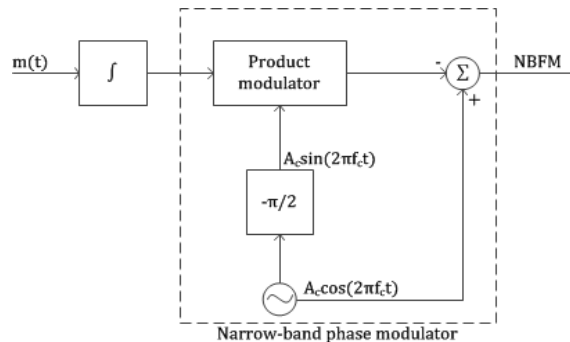

Fig: Narrowband FM Generator

The frequency deviation Δf is very small in narrow-band FM wave. To produce wideband FM, we have to increase the value of Δf to a desired level. This is achieved by means of one or multiple frequency multipliers. A frequency multiplier consists of a nonlinear device and a band pass filter. The n^{th} order nonlinear device produces a dc component and n number of frequency modulated waves with carrier frequencies $f_c, 2f_c \dots n f_c$ and frequency deviations $\Delta f, 2\Delta f \dots n\Delta f$, respectively. If we want an FM wave with frequency deviation of $6\Delta f$, then we may use a 6^{th} order nonlinear device or one 2^{nd} order and one 3^{rd} order nonlinear devices in cascade followed by a band pass filter centred at $6f_c$. Normally, we may require very high value of frequency deviation. This automatically increases the carrier frequency by the same factor which may be higher than the required carrier frequency. We may shift the carrier frequency to the desired level by using mixer which does not change the frequency deviation.

The narrowband FM has some distortion due to the approximation made in deriving the expression of narrowband FM from the general expression. This produces some amplitude modulation in the narrowband FM which is removed by using a limiter in frequency multiplier.

DEMODULATION OF FM WAVES

The demodulation process of FM waves is exactly opposite to that of the frequency modulation. After demodulation, we get the original modulating signal at the demodulation output.

Foster Seeley Discriminator-

The circuit diagram of phase discriminator or Foster Seeley Discriminator is given below

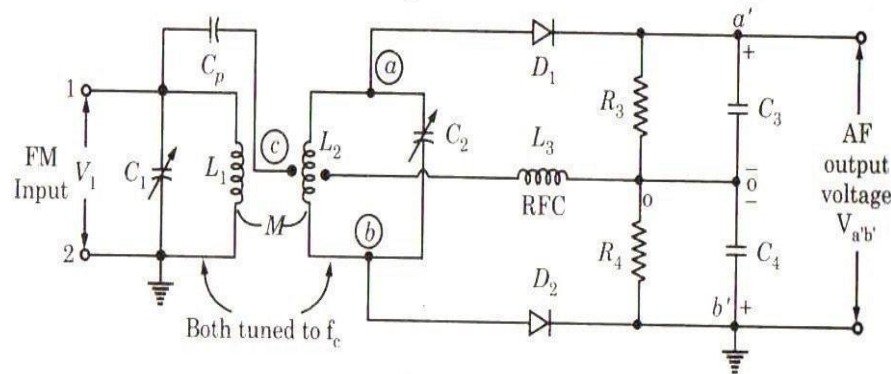

Fig3.2 Frequency Discriminator

This circuit consists of an inductively coupled double tuned circuit in which both primary and secondary coils are tuned to the same frequency. The center of the secondary coil is connected to the top of the primary through a capacitor C. this capacitor performs the functions are:

It blocks the D.C. from primary to secondary.

It couples the signal frequency from primary to center tapping of the secondary.

Advantages:

1. It is more easy to align than the balanced slope detector as there are only two tuned circuits and both are to be tuned at the same frequency f_c .
2. Linearity is better. This is because the operation of the circuit is dependent more on the primary to secondary relationship which is very much linear.

Drawbacks

It does not provide amplitude limiting. So in the presence of noise or any other spurious amplitude variations, the demodulator output responds to them and produce errors.

Unit-4

AM & FM TRANSMITTER & RECEIVER

AM radio receiver is a device which receives the desired AM signal, amplifies it followed by demodulation to get back the original modulating signal.

Radio receivers are broadly of TWO types

Depending on the application:

AM, FM, COMM., TV, RADAR

Depending on the fundamental principle

Tuned Radio Frequency (TRF) Receiver and Superheterodyne Receiver.

Tuned Radio Frequency (TRF) Receiver

The TRF receiver is a simple “logical” receiver. Two or three RF amplifiers, all tuning together, were employed to select and amplify the incoming frequency and simultaneously to reject all others. After the signal was amplified to a suitable level, it was demodulated (detected) and fed to the loud speaker after being passed through the appropriate audio amplifying stages. These are simple to design, align at broadcast frequencies, but they presented difficulties at higher frequencies.

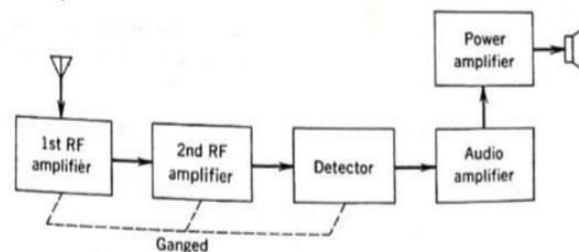

Block diagram of TRF receiver

SELECTIVITY-

It is a measure of the performance of radio receiver to respond only to respond only to the radio signal, it is tuned to and reject other signals nearby in frequency such as another broadcast on an adjacent channel.

SENSITIVITY-

The sensitivity of an electronic device, such as a communication system receiver, or detection device, is the minimum magnitude of input signal required to produce a specified output signal. Receiver sensitivity indicates how faint an input signal can be successfully received by the receiver.

FIDELITY-

It is the degree to which output of a system, such as an amplifier or radio, accurately reproduces the characteristics of the input signal.

NOISE FIGURE-

Noise figure is a measure of degradation of the signal to noise ratio, caused by components in a radio frequency signal. It is defined as the ratio of the signal to noise power ratio at the input to signal to noise power ratio at the output.

$$F = S_i/N_i$$

AM Transmitter:

Transmitter must generate a signal with the right type of modulation, with sufficient power, at the right carrier frequency, and with reasonable efficiency.

Earlier, we have studied the basic concepts of amplitude modulation. Now, we are going to study the two basic topologies to generate and transmit amplitude modulated waves. They are

Low level modulation

In low level modulation, the generation of AM wave takes place in the initial stage of amplification, i.e at a low power level. The generated AM signal then amplified using number of amplifier stages.

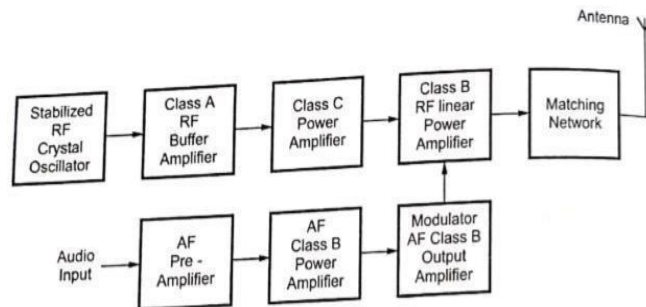

Block diagram of Low Level Modulation

High level modulation

In high level modulation, modulation takes place in the final stage of amplification and therefore modulation circuitry has to handle high power.

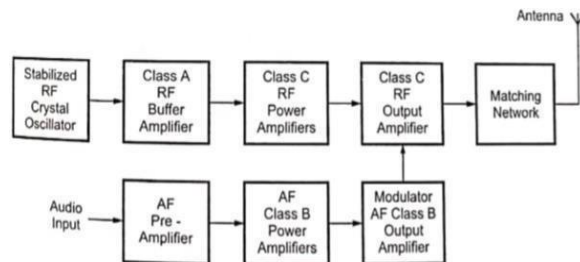

Block Diagram of High Level Modulation

It can be seen that stable RF source, buffer amplifier and subsequent RF power amplifiers are common for both low level modulation transmitter and high level modulation transmitter.

The stable RF source is provided by crystal oscillator with a carrier frequency or submultiple of it.

The buffer amplifiers are usually class-A amplifier whereas power amplifiers are class-C amplifiers in both, audio and power audio frequency (AF) amplifiers are present.

In fact, the only difference is the point at which the modulation takes place. In case of low level modulation, modulation takes place at low power level, i.e before the final output amplifier.

In low level modulation system amplifier efficiency and bandwidth preservations are important factors since audio signal is having low power.

For high level modulation other than efficiency of amplifier, power handling capability, distortion and capability of handling amplitude variations are important parameter.

The output of final amplifier is passed through an impedance matching network that includes the tank circuit of the final amplifier. For tank circuits, Q is kept low enough to pass all sideband signals without amplitude and frequency distortion.

AM Super heterodyne Receiver:

Heterodyning action is a process of combining two ac signals of different frequency in-order to obtain signals of new frequencies. A circuit called mixer or converter is used for heterodyning two signals. If f_1 and f_2 are the two frequencies combined, then heterodyning results in two components

The sum component with frequency $f_1 + f_2$ which is filtered out using a band pass filter.

The difference component with frequency $f_1 - f_2$ is retained and processed.

In case of super heterodyne receiver the RF carrier f_c is heterodyned with a higher RF local signal f_s (From Local Oscillator or BFO) so that the output difference component ($f_s - f_c$) is always of frequency 455kHz.

The block diagram of the super heterodyne receiver is as shown in the figure

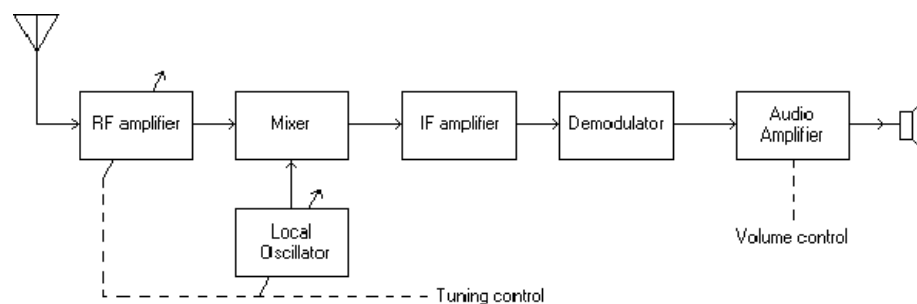

Super-Heterodyne Receiver

RF Tuning and Amplification: The modulated RF waves travel through space and reach the antenna of the super heterodyne receiver situated in a remote location. The receiver is attached to a tuning amplifier circuit which receives and amplifies the modulated RF carrier.

Heterodyning using Mixer : The output of the tuning circuit is fed to the mixer which combines modulated RF with a high frequency RF signals generated by a local oscillator (BFO - Beat Frequency Oscillator) to produce modulated IF signals. To maintain the constant frequency of IF signals output by the mixer at 455kHz, principle of ganged tuning is used. The ganged tuning is a process in which the tuning circuit and the local oscillator are connected to ganged capacitor circuit. The change in the capacitance of the ganged capacitor will keep the tuned frequency and the local oscillator frequency such that the output of the mixer is of frequency 455kHz.

IF amplification: The output of the mixer is fed to the IF amplifier which amplifies the modulated IF signal and increases its amplitude without modifying its waveform.

Demodulation: The amplified IF signal from the IF amplifier is input to the demodulator (Detector). The demodulator consists of a diode circuit which will eliminate the negative portion of the signal. Thus only positive portion of the modulated IF signal is output and fed to the next stage of AF amplification. Thus the demodulator converts the modulated IF into AF signal.

AF amplification: The output of the demodulator is fed to AF amplification stage. In this stage the AF signal is amplified.

Transduction: The amplified AF signal is input to the transducer which is a speaker. Speaker converts the AF signal into speech or intelligence. The process of conversion is called transduction.

Waveforms: The output waveform at the each stage of the superheterodyne receiver is as shown in the figure 6. Thus the reception of modulated RF carrier by super heterodyne receiver and converting the same into speech or intelligence is explained.

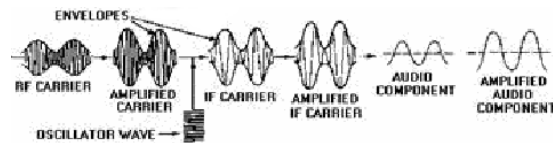

Super-Heterodyne Receiver Waveforms

Unit-5

ANALOG TO DIGITAL CONVERSION & PULSE MODULATION SYSTEM.

Sampling

It is a process of conversion of a continuous time signal into a discrete time signal. During this process discrete signal values are taken at discrete time intervals.

Sampling Theorem:

A continuous time signal may be completely represented by its samples and can be recovered back, if the sampling is done at a sampling frequency greater than or equal to twice of the maximum signal frequency present in the signal.

$$\text{i.e } f_s \geq 2f_m$$

where, $f_s \rightarrow$ Sampling Frequency

$f_m \rightarrow$ Maximum Frequency Present in the Signal.

Nyquist Rate:

When the sampling frequency or rate of sampling is exactly equal to $2f_m$ samples per second then it is called as "Nyquist Rate" i.e Nyquist rate, $f_s = 2f_m$

Nyquist Interval:

It is the maximum sampling interval

so Nyquist Interval, $T_s = 1/f_s = 1/2f_m$

Types of Sampling:

Instantaneous Sampling.

Natural Sampling.

Flat-Top Sampling

Instantaneous Sampling or Impulse Sampling:

In this sampling, the amplitude of sampled signal at any instant is equal to the input signal value at that instant. During this the sampling frequency is kept very high. i.e $f_s \gg \gg 2f_m$. It is not practical.

Natural Sampling:

In this sampling, the sampled signal consists of a sequence of pulses of varying amplitude whose tops are not flat but follow the input signal values. Here the sampling rate, $f_s \geq 2f_m$.

Flat-Top Sampling:

In this sampling, the sampled signal consists of a sequence of pulses of varying amplitude but having flat tops. Here also the sampling rate, $f_s \geq 2f_m$.

Aliasing:

If a signal is sampled at a sampling rate below ' $2f_m$ ' then the sampled spectrum will overlap with each other. This overlapping is called as 'Aliasing'. Due to aliasing it is not possible to recover signal from its sampled values. To avoid aliasing a low-pass filter is used before sampling which blocks the frequencies which are above ' f_m '.

Pulse Modulation

In analog modulation systems, some parameter of a sinusoidal carrier is varied according to the instantaneous value of the modulating signal. In Pulse modulation methods, the carrier is no longer a continuous signal but consists of a pulse train. Some parameter of which is varied according to the instantaneous value of the modulating signal.

Types of Pulse Modulation:

Pulse Analog Modulation

Pulse Amplitude Modulation (PAM)

Pulse Width Modulation (PWM)

Pulse Position Modulation (PPM)

Pulse Digital Modulation

Pulse Code Modulation (PCM)

Differential Pulse Code Modulation (DPCM)

Delta Modulation (DM) & Adaptive Delta Modulation (ADM)

Pulse Amplitude Modulation

The amplitude of the pulses of the carrier pulse train is varied in accordance with the modulating signal, that is amplitude of the pulses depends on the value of $m(t)$ during the time of pulse.

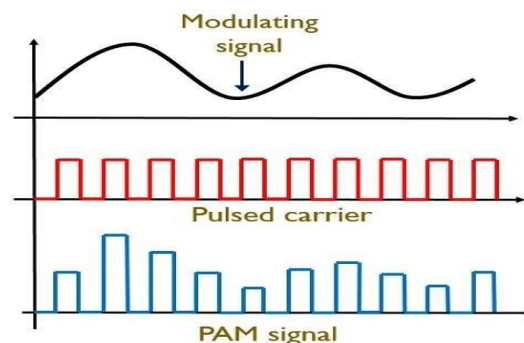

In fact the pulses in a PAM signal may of Flat-top type or natural type or ideal type. The Flat-top PAM is most popular and is widely used. The reason for using Flat-top PAM is that during the transmission, the noise interferes with the top of the transmitted pulses and this noise can be easily removed if the PAM pulse as Flat-top. In natural samples PAM signal, the pulse has varying top in accordance with the signal variation. Such type of pulse is received at the receiver, it is always contaminated by noise. Then it becomes quite difficult to determine the shape of the top of the pulse and thus amplitude detection of the pulse is not exact.

Generation of PAM

There are two operations involved in the generation of PAM signal. Instantaneous sampling of the message signal $m(t)$ every T_s seconds, where the sampling rate $f_s = 1/T_s$ is chosen in accordance with the sampling theorem. Lengthening the duration of each sample so obtained to some constant value T .

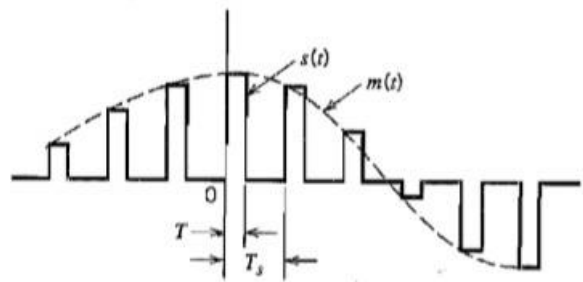

Sample and Hold Circuit for Generating Flat-top sampled PAM

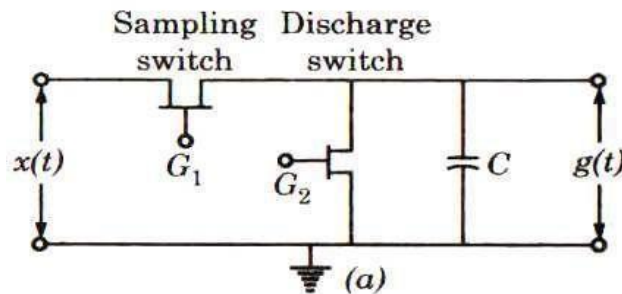

The sample and hold circuit consists of two Field Effect Transistor switches and a capacitor. The sampling switch is closed for a short duration by a short pulse applied to the gate G_1 of the transistor. During this period, the capacitor C is quickly charged up to a voltage equal to the instantaneous sample value of the incoming signal. Now, the sampling switch is opened and the capacitor holds the charge. The discharge switch is then closed by a pulse applied to gate G_2 of the other transistor. Due to this, the capacitor is discharged to zero volts. The discharge switch is then opened and thus capacitor has no voltage. Hence the output of the sample and hold circuit consists of a sequence of flat-top samples as shown in figure.

Demodulation of PAM

In this method, the received PAM signal is allowed to pass through a holding circuit and a low pass filter. In the holding circuit the switch s is closed after the arrival of the pulse and it is opened at the end of the pulses. In this way, the capacitor C is charged to the pulse amplitude value and it holds this value during the interval between the two pulses. After this the holding circuit output is smoothed in low pass filter. It may be observed

that some kind of distortion is introduced due to the holding circuit. Here we use a zero order holding circuit. This zero order holding circuit considers only the previous sample to decide the value between the two pulses.

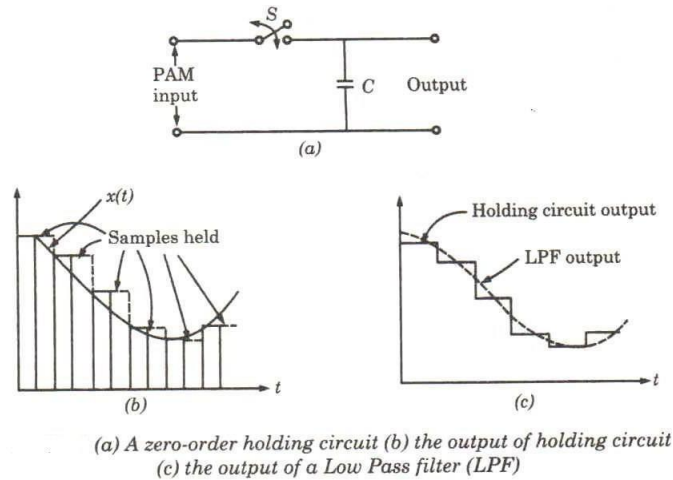
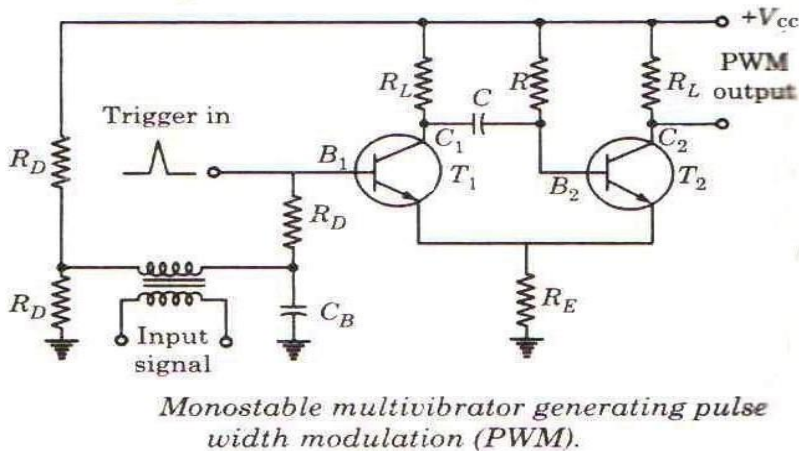

Fig: PAM signal generator generating modulating Signal

GENERATION OF PWM -

It is basically a monostable multivibrator with a modulating input signal applied at the control voltage input. Internally, the control voltage is adjusted to the $2/3 V_{cc}$. Externally applied modulating signal changes the control voltage, and hence the threshold voltage level. As a result, the time period required to charge the capacitor up to threshold voltage level changes, giving pulse modulated signal at the output.



The stable state for above circuit is achieved when T_1 is OFF and T_2 is ON. The positive going trigger pulse at B_1 switches T_1 ON. Because of this, the voltage at C_1 falls as T_1 begins to draw the collector current. As a result, voltage at B_2 also falls and T_2 is switched OFF, C begins to charge up to the collector supply voltage through resistor R . After a time determined by the supply voltage and the RC time constant of the charging network, the

base of the T2 becomes sufficiently positive to switch T2 ON. The transistor T1 is simultaneously switched OFF by regenerative action and stays OFF until the arrival of the next trigger pulse. To make T2 ON, the base of the T2 must be slightly more positive than the voltage across resistor R_e . This voltage depends on the emitter current I_e which is controlled by the signal voltage applied at the base of transistor T1. Therefore, the changing voltage necessary to turn OFF transistor T2 is decided by the signal voltage. If signal voltage is maximum, the voltage that capacitor should charge to turn ON T2 is also maximum. Therefore, at maximum signal voltage, capacitor has to charge to maximum voltage requiring maximum time to charge. This gives us maximum pulse width at maximum input signal voltage. At minimum signal voltage, capacitor has to charge for minimum voltage and we get minimum pulse width at the output.

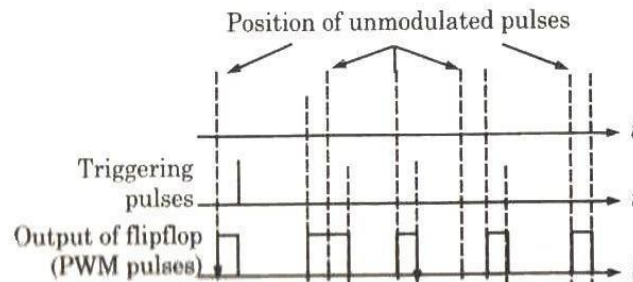

DEMODULATION OF PWM-

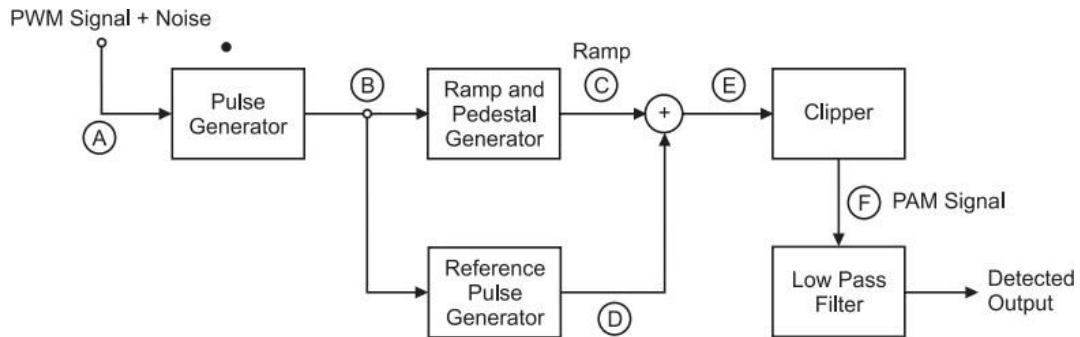

PWM Detector

The received PWM signal is applied to the Schmitt trigger circuit. This Schmitt trigger circuit removes the noise in the PWM waveform. The regenerated PWM is then applied to the ramp generator and the synchronization pulse detector. The ramp generator produces ramps for the duration of pulses such that height of ramps are proportional to the widths of PWM pulses. The maximum ramp voltage is retained till the next pulse. On the other hand, synchronous pulse detector produces reference pulses with constant amplitude and pulse width. These pulses are delayed by specific amount of delay. The delayed reference pulses and the output of ramp generator is added with the help of adder. The output of adder is given to the level shifter. Here negative offset shifts the waveform. Then the negative part of the waveform is clipped by rectifier. Finally, the output of rectifier is passed through low pass filter to recover the modulating signal.

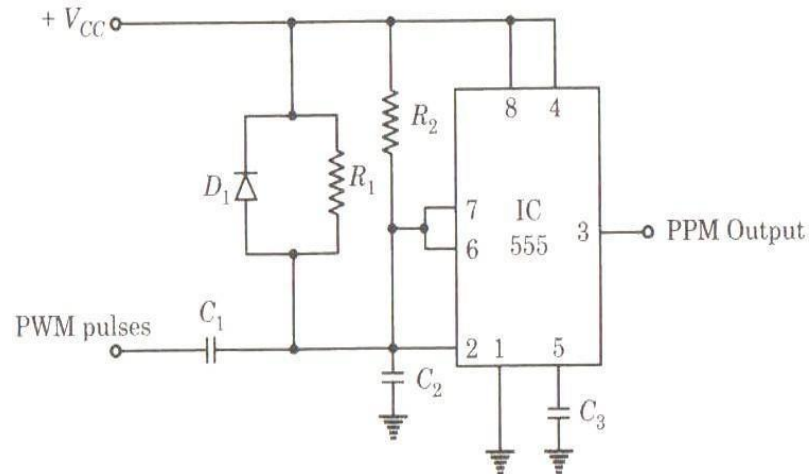
GENERATION OF PPM SIGNAL-

PPM Generator

It consists of differentiator and a mono-stable multivibrator. The input to the differentiator is a PWM waveform. The differentiator generates positive and negative spikes corresponding to leading and trailing edges of the PWM waveform. Diode D_1 is used to bypass the positive spikes. The negative spikes are used to the trigger monostable multivibrator. The monostable multivibrator then generates the pulses of same width and amplitude with reference to trigger to give pulse position modulated waveform.

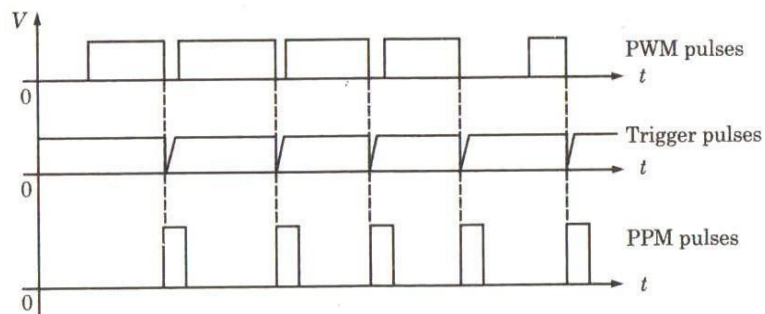

PPM generated Waveform

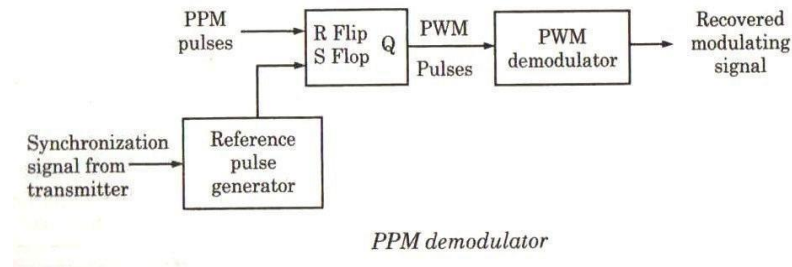
DEMODULATION OF PPM

Flip flop is set or turned ON when the reference pulse arrives. This reference pulse is generated by reference pulse generator of the receiver with the synchronization signal from the transmitter. The flip flop circuit is reset or turned OFF at the leading edge of position modulated pulse. This repeats and we get PWM pulses at the output of the flip flop.

QUANTIZATION:-

The process of representing continuous amplitude level to a constant finite amplitude level is quantization. Quantization makes the range of a signal discrete, so that the quantized signal takes on only a discrete, usually finite, set of values. Unlike sampling quantization is generally irreversible and results in loss of information. It therefore introduces distortion into the quantized signal that cannot be eliminated.

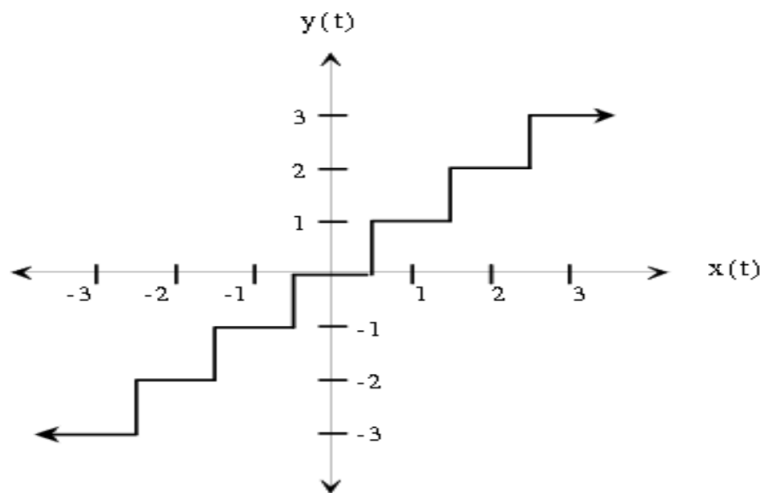

Zero Memory Quantizer figure

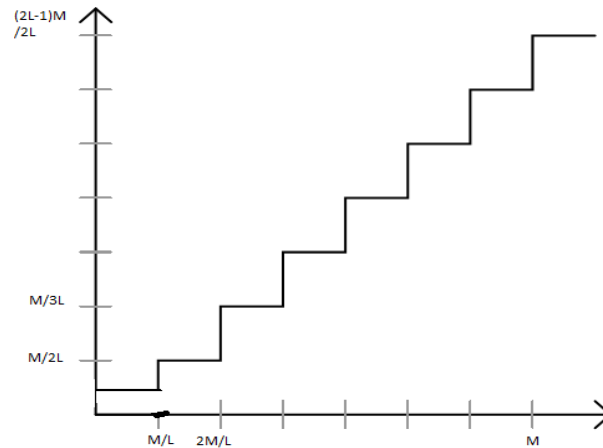

A uniform Quantizer figure

QUANTIZATION NOISE & QUANTIZATION ERROR:

The difference between the baseband signal $m(t)$ and quantized signal $m_q(t)$ is known as quantization noise. Quantization error is nothing but the error due to quantization noise.

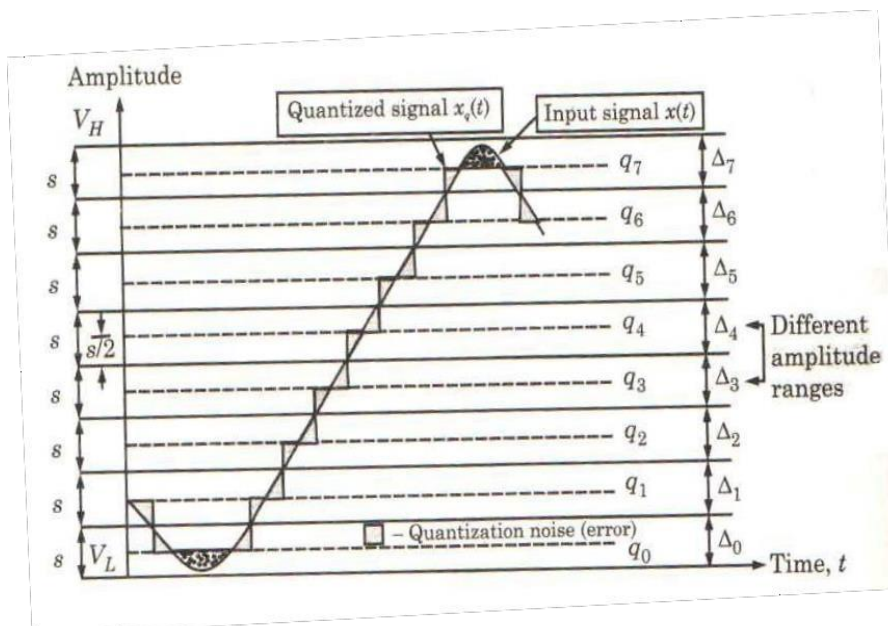

Illustration of Quantization Process

$x_q(t)$ represents the quantized version of $x(t)$. $x_q(t)$ is obtained at the output of the quantizer. When $x(t)$ is in the range Δ_0 , then corresponding to any value of $x(t)$, the quantizer output will be equal to q_0 . Thus in each range from

$\Delta 0$ and $\Delta 7$, the signal $x(t)$ is rounded off to the nearest quantization level and the quantized signal is produced. The quantized signal $x_q(t)$ is thus an approximation of $x(t)$. The difference between them is called as Quantization Error or Quantization noise.

$$\varepsilon = x_q(t) - x(t)$$

PULSE CODE MODULATION-

Pulse code modulation is known as a digital pulse modulation technique. The pulse code modulation is quite complex compared to the analog pulse modulation techniques.

A PCM system consists of 3 main parts i.e, transmitter, transmission path and receiver. The essential operations in the transmitter of a PCM system are sampling, quantizing and encoding. Sampling is the operation in which an analog signal is sampled according to the sampling theorem resulting in a discrete time signal. The quantizing and encoding operations are usually performed in same circuit which is known as an analog to digital converter. Also the essential operations in the receiver are regeneration of impaired signals, decoding and demodulation of the train of quantized samples.

PCM Transmitter:

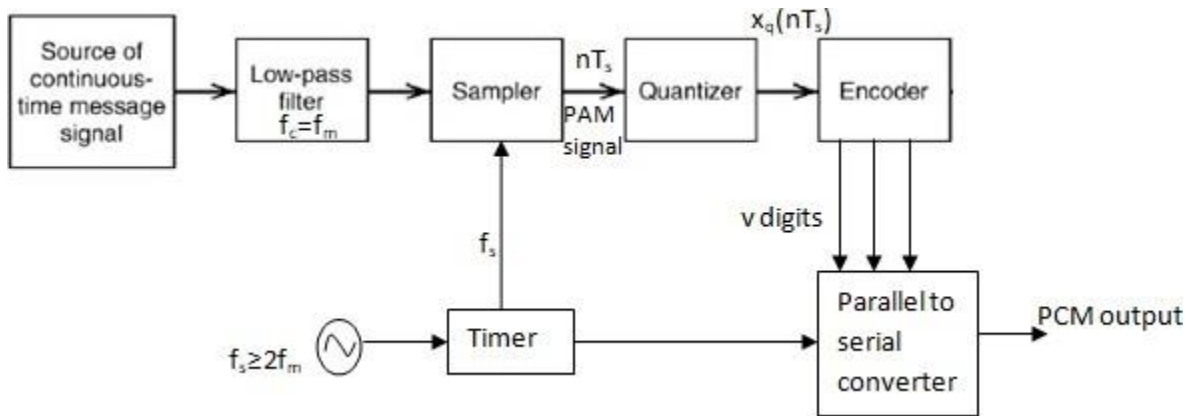

In PCM transmitter, the signal $x(t)$ is first passed through the low-pass filter of cut-off frequency f_m Hz. This low-pass filter blocks all the frequency components above f_m Hz. This means that now the signal $x(t)$ is band limited to f_m Hz. The sample and hold circuit then samples this signal at the rate of f_s . Sampling frequency f_s is selected sufficiently above nyquist rate to avoid aliasing i.e., $f_s \geq 2f_m$. In fig.2, the output of sample and hold circuit is denoted by $x(nT_s)$. This signal $x(nT_s)$ is discrete in time and continuous in amplitude. A q -level quantizer compares input $x(nT_s)$ with its fixed digital levels. It then assigns any one of the digital level to $x(nT_s)$ which results in minimum distortion or error. This error is called quantization error. Thus output of quantizer is a digital level called $x_q(nT_s)$. Now the quantized signal level $x_q(nT_s)$ is given to binary encoder. This encoder converts input signal to ' v ' digits binary word. This encoder is also known as digitizer. In addition to these, there is an oscillator which generates the clocks for sample and hold circuit and parallel to serial converter. In PCM, sample and hold, quantizer and encoder combine to form an analog to digital converter (ADC).

PCM Receiver:

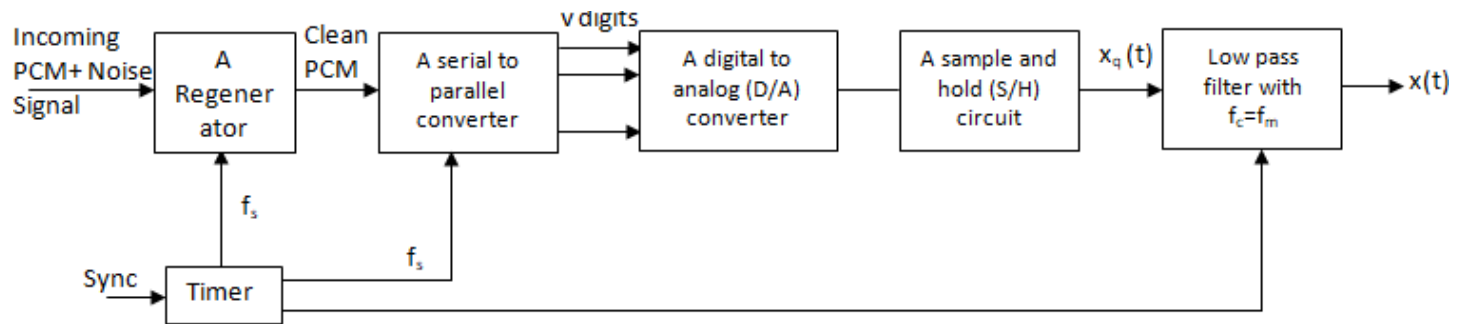

The regenerator at the start of PCM receiver reshapes the pulse and removes the noise. This signal is then converted to parallel digital words for each sample. Now, the digital word is converted to its analog value denoted as $x_q(t)$ with the help of a sample and hold circuit. This signal, at the output of sample and hold circuit is allowed to pass through a low-pass reconstruction filter to get the original message signal $x(t)$.

COMPANDING IN PCM-

When the steps are uniform in size, the small amplitude signals would have a poorer signal to quantization noise ratio than the large amplitude signals, since in both the cases the denominator is the same whereas the numerator order is quite small for small amplitude signals and large for large amplitude signals. Since we have to use a fixed number of quantization levels, the only way to have a uniform signal to quantization noise ratio is to adjust the step size in such a manner that the ratio remains constant. This means that the step size must be small for small amplitude signals and large for large amplitude signals.

The effect of an adaptive step size may be achieved in a more feasible way by distorting the signal before the quantization process. An inverse distortion has to be introduced at the receiver to make the overall transmission distortionless.

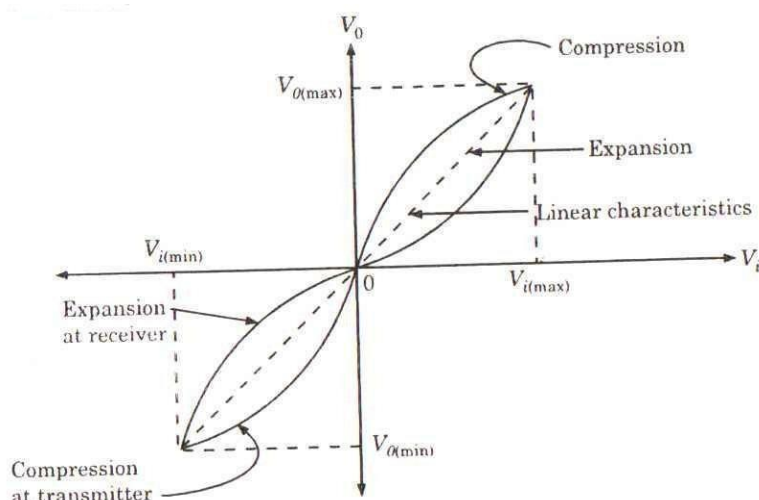

Companding in PCM

Therefore, the signal amplified at low signal levels and attenuated at high signal levels. After this process, uniform quantization is used. This is equivalent to more step size at low signal levels and small step size at high signal levels. At the receiver a reverse process is done. This means that the signal is attenuated at low signal levels and amplified at high levels to get original signal. Thus the compression of signal at transmitter and expansion at receiver is combinely known as companding.

VOCODER

The source coders employed are called VOCODERS (voice coders) and they operate at a significantly lower bit rate than even ADM. VOCODER bit rates are the range 1.2 to 2.4 kb/s. The resulting reproduced voice has a synthetic – sounding and a somewhat artificial quality. As a result VOCODERS are employed for special application where it acceptable to trade speech quality for the advantage of low bit rate. To transmit speech we need not transmit the pre size waveform generated by the speaker. Rather we can transmit information from which a waveform can be reconstructed at the receiver which is only similar to, rather than identical to, the wave form generated by the speaker.

Application are found in military communication, operated recorded messages, etc

T-carrier system-

The basic time division multiplexing scheme called the T- carrier system, which is used to convey multiple signals over telephone lines using wideband coaxial cable. It accommodates 24 analog signals which are referred as S1 to S24. Each signal is band limited to approximately 3.3khz and is sampled at the rate of 8khz..

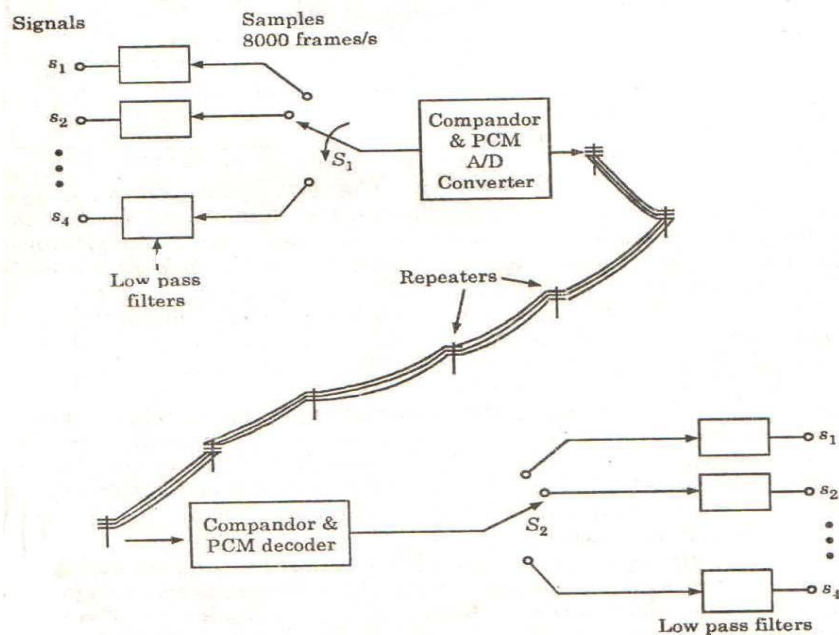

A T1 carrier system

Each of the time division multiplexed signals is next A/D converted and compounded. The resulting digital waveform is transmitted over a coaxial cable, the cable serving to minimize signal distortion and serving also to suppress signal distortion due to noises from external sources. Periodically, at approximately 6000ft intervals the signal is regenerated by amplifiers known as repeaters and then sent towards its destination. The repeater eliminates from each bit the effect of the distortion introduced by the channel. Also the repeater removes from each bit any

superimposed noise and thus, even having received a distorted and noisy signal, it retransmits a distortion less and noise free signal which was originally sent.

At the destination, the signal is companded, decoded and demultiplexed and thus making available the 24 original signals individual.

TIME DIVISION MULTIPLEXING-

In case of Time Division Multiplexing (TDM), the complete channel bandwidth is allotted to one user for a fixed time slot. As an example, if there are ten users, then every user can be given the time slot of one second. Thus, complete channel can be used by each user for one second time in every ten seconds. This technique is suitable for digital signals.

Operation-

In Time Division Multiplexed system, different time intervals rather than frequencies are allotted to different signals. During these intervals, these signals are sampled and transmitted. Thus, this system transmits information intermittently rather than continuously. Continuously varying analogue signals have to be sampled at proper intervals for transmission and the receiver must recognize these samples for TDM system to properly.

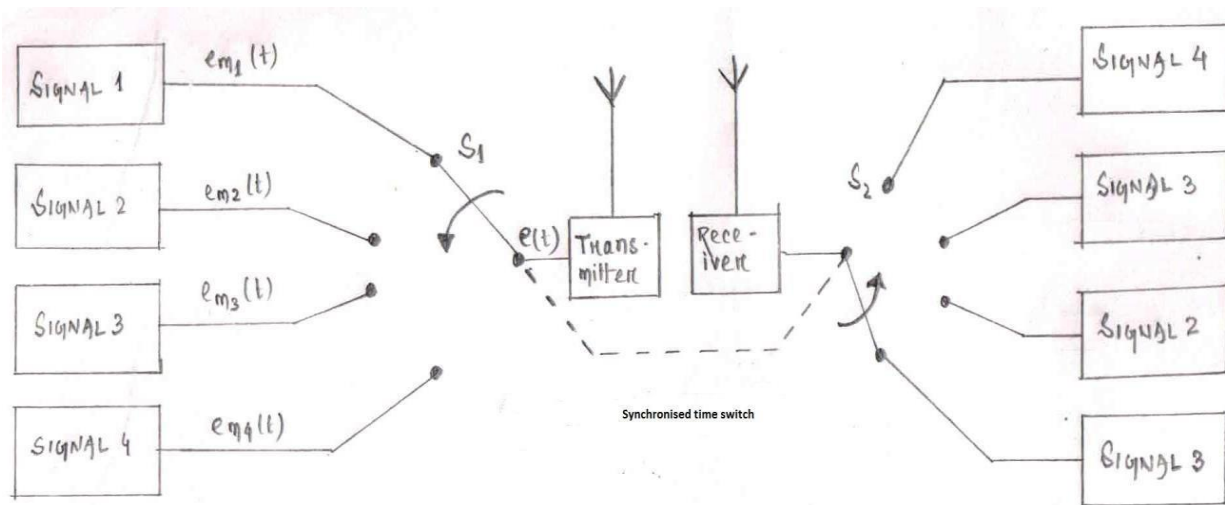

Time Division Multiplexing

Each signal source is switched in for a fixed time interval by a time switch S_1 . During this time, the connected signal modulates the carrier of the transmitter. The switch then moves to the next position connecting the second signal to the transmitter. The process is repeated by the time switch which must rotate continuously at a uniform speed for proper operation of the system. The time for which a signal is connected to the transmitter and the time gap between the instants when the first signal is disconnected and second is connected to the transmitter is very important. The time for which a signal remains connected to the transmitter and the frequency at which the switch rotates are important and related to the highest frequency in the signal. The relationship between them is governed by the sampling theorem.

Introduction to Delta Modulation

The sampling rate of a signal should be higher than the Nyquist rate, to achieve better sampling. If this sampling interval in a Differential PCM (DPCM) is reduced considerably, the sample-to-sample amplitude difference is very small, as if the difference is **1-bit quantization**, then the step-size is very small i.e., Δ (delta).

What is Delta Modulation?

The type of modulation, where the sampling rate is much higher and in which the stepsize after quantization is of smaller value Δ , such a modulation is termed as delta modulation.

Features of Delta Modulation

- An over-sampled input is taken to make full use of a signal correlation.
- The quantization design is simple.
- The input sequence is much higher than Nyquist rate.
- The quality is moderate.
- The design of the modulator and the demodulator is simple.
- The stair-case approximation of output waveform.
- The step-size is very small, i.e., Δ (delta).
- The bit rate can be decided by the user.
- It requires simpler implementation.

Delta Modulation is a simplified form of DPCM technique, also viewed as 1-bit DPCM scheme. As the sampling interval is reduced, the signal correlation will be higher.

Delta Modulator

The Delta Modulator comprises of a 1-bit quantizer and a delay circuit along with two summer circuits. Following is the block diagram of a delta modulator.

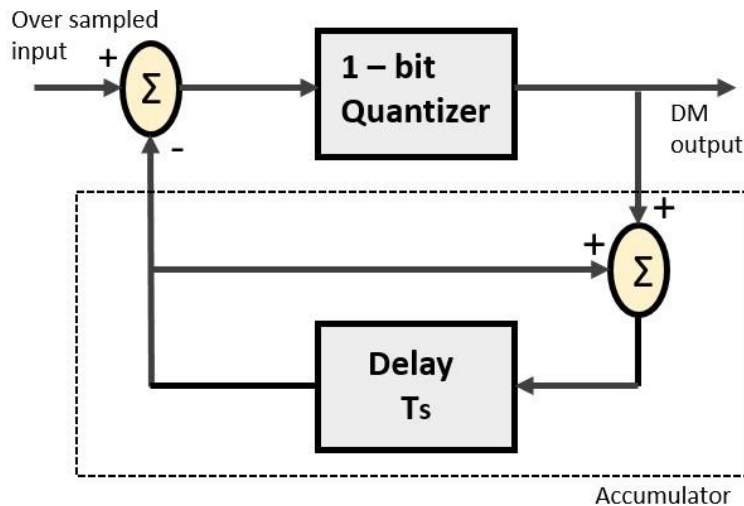

A stair-case approximated waveform will be the output of the delta modulator with the step-size as delta (Δ). The output quality of the waveform is moderate.

Delta Demodulator

The delta demodulator comprises of a low pass filter, a summer, and a delay circuit. The predictor circuit is eliminated here and hence no assumed input is given to the demodulator.

Following is the block diagram for delta demodulator.

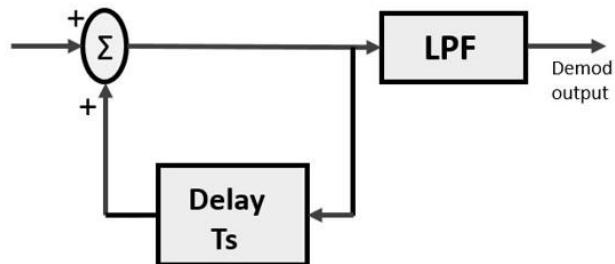

Low pass filter is used for many reasons, but the prominent one is noise elimination for out-of-band signals. The step-size error that may occur at the transmitter is called granular noise, which is eliminated here. If there is no noise present, then the modulator output equals the demodulator input.

Advantages of DM over DPCM

- 1-bit quantizer
- Very easy design of modulator & demodulator

However, there exists some noise in DM and following are the types of noise.

- Slope Over load distortion (when Δ is small)
- Granular noise (when Δ is large)

Adaptive Delta Modulation

In digital modulation, we come across certain problems in determining the step-size, which influences the quality of the output wave.

The larger step-size is needed in the steep slope of modulating signal and a smaller stepsize is needed where the message has a small slope. As a result, the minute details get missed. Hence, it would be better if we can control the adjustment of step-size, according to our requirement in order to obtain the sampling in a desired fashion. This is the concept of Adaptive Delta Modulation (ADM).

Block Diagram

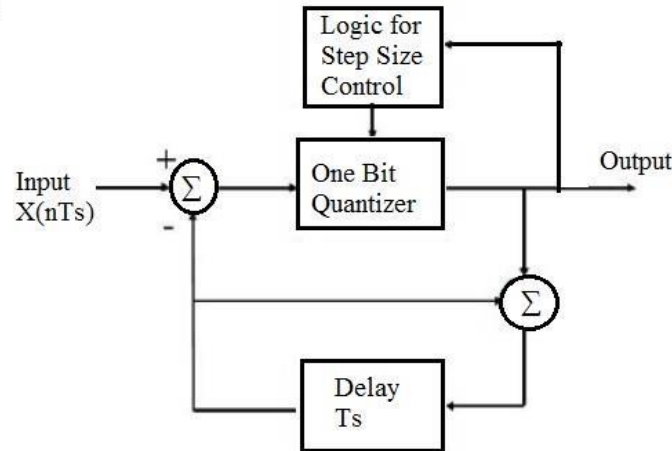

The transmitter circuit consists of a summer, quantizer, Delay circuit, and a logic circuit for step size control. The baseband signal $X(nT_s)$ is given as input to the circuit. The feedback circuit present in the transmitter is an Integrator. The integrator generates the staircase approximation of the previous sample.

At the summer circuit, the difference between the present sample and staircase approximation of previous sample $e(nT_s)$ is calculated. This error signal is passed to the quantizer, where a quantized value is generated. The step size control block controls the step size of the next approximation based on either the quantized value is high or low. The quantized signal is given as output.

At the receiver end Demodulation takes place. The receiver has two parts. First part is the step size control. Here the received signal is passed through a logic step size control block, where the step size is produced from each incoming bit. Step size is decided based on present and previous input. In the second part of the receiver, the accumulator circuit recreates the staircase signal. This waveform is then applied to a low pass filter which smoothens the waveform and recreates the original signal.

Adaptive Delta Modulation Theory

In Adaptive Delta Modulation, the step size of the staircase signal is not fixed and changes depending upon the input signal. Here first the difference between the present sample value and previous approximation is calculated. This error is quantized i.e. if the present sample is smaller than the previous approximation, quantized value is high or else it is low. The output of the one-bit quantizer is given to the Logic step size control circuit where the step size is decided.

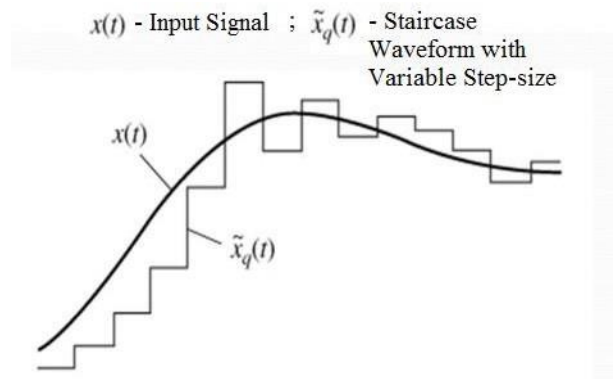

At the logic step size control circuit, the output is decided based on the quantizer output. If the quantizer output is high, then the step size is doubled for the next sample. If the quantizer output is low, the step size is reduced by one step for the next sample.

Advantages

- Adaptive delta modulation decreases slope error present in delta modulation.
- During demodulation, it uses a low pass filter which removes the quantized noise.
- The slope overload error and granular error present in delta modulation are solved using this modulation. Because of this, the signal to noise ratio of this modulation is better than delta modulation.
- In the presence of bit errors, this modulation provides robust performance. This reduces the need for error detection and correction circuits in radio design.
- The dynamic range of Adaptive delta modulation is large as the variable step size covers large range of values.

Differences between Delta Modulation and Adaptive Delta Modulation

- In Delta Modulation step size is fixed for the whole signal. Whereas in Adaptive delta modulation, the step size varies depending upon the input signal.
- The slope overload and granular noise errors which are present in delta modulation are not seen in this modulation.
- The dynamic range of Adaptive delta modulation is wider than delta modulation.
- This modulation utilizes bandwidth more effectively than delta modulation.

Unit-6

DIGITAL MODULATION TECHNIQUES

Digital Modulation provides more information capacity, high data security, quicker system availability with great quality communication. Hence, digital modulation techniques have a greater demand, for their capacity to convey larger amounts of data than analog ones.

There are many types of digital modulation techniques and we can even use a combination of these techniques as well. In this chapter, we will be discussing the most prominent digital modulation techniques. If the information signal is digital and the amplitude of the carrier is varied proportional to the information signal, a digitally modulated signal called amplitude shift keying (ASK) is produced. If the frequency (f) is varied proportional to the information signal, frequency shift keying (FSK) is produced, and if the phase of the carrier (θ) is varied proportional to the information signal, phase shift keying (PSK) is produced. If both the amplitude and the phase are varied proportional to the information signal, quadrature amplitude modulation (QAM) results. ASK, FSK, PSK, and QAM are all forms of digital modulation.

Amplitude Shift Keying

The amplitude of the resultant output depends upon the input data whether it should be a zero level or a variation of positive and negative, depending upon the carrier frequency.

Amplitude Shift Keying (ASK) is a type of Amplitude Modulation which represents the binary data in the form of variations in the amplitude of a signal.

Following is the diagram for ASK modulated waveform along with its input.

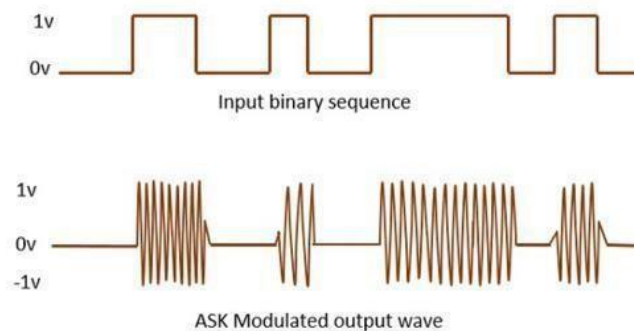

Any modulated signal has a high frequency carrier. The binary signal when ASK is modulated, gives a zero value for LOW input and gives the carrier output for HIGH input.

Mathematically, amplitude-shift keying is

$$v_{(ask)}(t) = [1 + v_m(t)] \left[\frac{A}{2} \cos(\omega_c t) \right]$$

where $v_{ask}(t)$ = amplitude-shift keying wave

$v_m(t)$ = digital information (modulating) signal (volts)

$A/2$ = unmodulated carrier amplitude (volts)

ω_c = analog carrier radian frequency (radians per second, $2\pi f_c t$)

In above Equation, the modulating signal [$v_m(t)$] is a normalized binary waveform, where +1 V = logic 1 and -1 V = logic 0. Therefore, for a logic 1 input, $v_m(t) = +1$ V, Equation 2.12 reduces to

$$\begin{aligned} v_{(ask)}(t) &= [1 + 1] \left[\frac{A}{2} \cos(\omega_c t) \right] \\ &= \underline{A \cos(\omega_c t)} \end{aligned}$$

Mathematically, amplitude-shift keying is (2.12) where $v_{ask}(t)$ = amplitude-shift keying wave

$v_m(t)$ = digital information (modulating) signal (volts) $A/2$ = unmodulated carrier amplitude (volts)

ω_c = analog carrier radian frequency (radians per second, $2\pi f_c t$) In Equation 2.12, the modulating signal

[$v_m(t)$] is a normalized binary waveform, where +1 V = logic 1 and -1 V = logic 0. Therefore,

for a logic 1 input, $v_m(t) = +1$ V, Equation 2.12 reduces to and for a logic 0 input, $v_m(t)$

= -1 V, Equation reduces to

$$\underline{v_{(ask)}(t) = [1 - 1] \left[\frac{A}{2} \cos(\omega_c t) \right]}$$

Thus, the modulated wave $v_{ask}(t)$, is either $A \cos(\omega_c t)$ or 0. Hence, the carrier is either "on" or "off," which is why amplitude-shift keying is sometimes referred to as on-off keying (OOK).

it can be seen that for every change in the input binary data stream, there is one change in the ASK waveform, and the time of one bit (t_b) equals the time of one analog signaling element (t_s). $B = f_b/1 = f_b$ baud = $f_b/1 = f_b$

ASK TRANSMITTER:

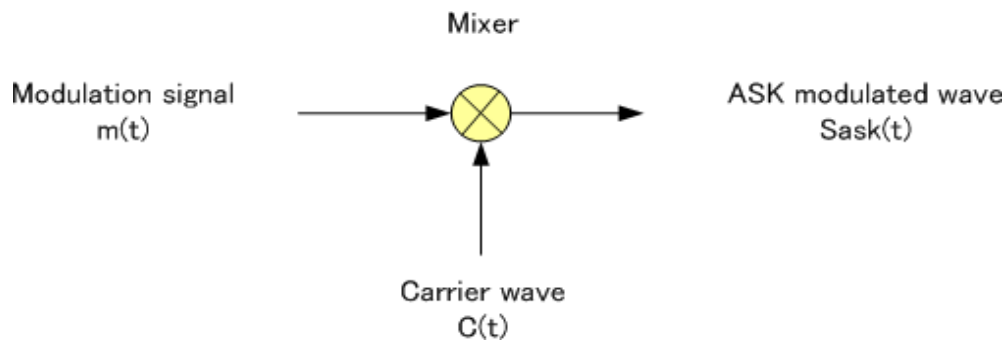

The input binary sequence is applied to the product modulator. The product modulator amplitude modulates the sinusoidal carrier .it passes the carrier when input bit is '1' .it blocks the carrier when input bit is '0'.

Coherent ASK Detector:

The demodulation of binary ASK waveform can be achieved with the help of coherent detector. It consists of a product modulator which is followed by an integrator and a decision making device. The incoming ASK signal is applied to one input of the product modulator. The other input of the product modulator is supplied with a sinusoidal carrier which is generated with the help of a local oscillator. The output of the product modulator goes to input of the integrator. The integrator operates on the output of the product modulator for successive bit intervals and essentially performs a low pass filtering action. The output of the integrator goes to the input of a decision making device.

Then the decision making device compares the output of the integrator with a preset threshold. It makes a decision in favors of symbol '1' when the threshold is exceeded and in favors of symbol '0' otherwise.

COHERENT DETECTION OF ASK

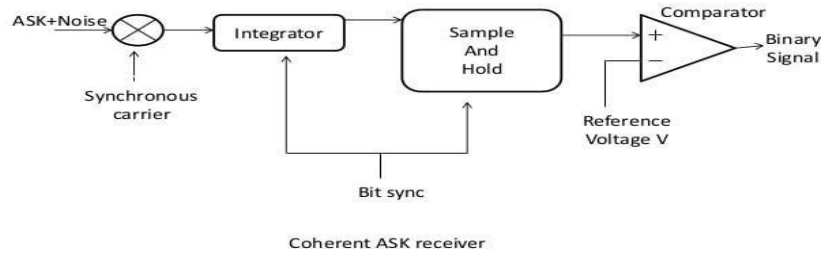

GENERATION AND DETECTION OF BFSK-

BINARY FREQUENCY SHIFT KEYING (BFSK)

In binary frequency shift keying, the frequency of the carrier is shifted according to the binary symbol. However the phase of the carrier is unaffected. We have two different frequency signals according to binary symbols.

If $b(t) = 1$, then $S_H(t) = \sqrt{2P_s} \cos(2\pi f_c t + \Omega)t$

$b(t) = 0$, then $S_L(t) = \sqrt{2P_s} \cos(2\pi f_c t - \Omega)t$

the equation combinely written as

$$S(t) = \sqrt{2P_s} \cos[(2\pi f_c t + d(t)\Omega)t]$$

Hence if symbol 1 is to be transmitted the carrier frequency will be $f_c + \Omega/2\pi$ Hence

if symbol 0 is to be transmitted the carrier frequency will be $f_c - \Omega/2\pi$ Therefore, we

have

$$f_H = f_c + \Omega/2\pi \text{ for symbol } 1$$

$$f_L = f_c - \Omega/2\pi \text{ for symbol } 0$$

GENERATION OF BFSK:-

The input sequence $b(t)$ is same as $P_H(t)$. An inverter is added after $b(t)$ to get $P_L(t)$. The level shifter $P_H(t)$ and $P_L(t)$ are unipolar signals. The level shifter converts the 1 level to $\sqrt{P_s T_b}$. Zero level is unaffected. Thus the output of the level shifters will be either $\sqrt{P_s T_b}$ (if input is 1) or zero (if input is zero). Further, there are product modulators after level shifter. The two carrier signals $\Phi_1(t)$ & $\Phi_2(t)$ are used. $\Phi_1(t)$ & $\Phi_2(t)$ are orthogonal to each other. The carrier signal multiplied with the output of the level shifter in product modulator.

The adder then adds the two signals from product modulator.

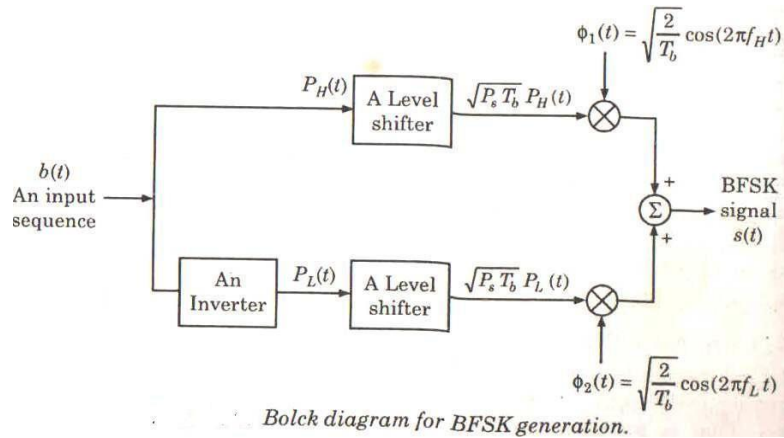

DETECTION OF BFSK-

This receiver contains two band pass filters, one with centre frequency f_{c1} and other with centre frequency f_{c2} . Because $f_{c1} - f_{c2} = 2fb$, the outputs of filters do not overlap each other. The band pass filters pass their corresponding main lobes without much distortion. The outputs of filters are applied to envelope detectors. The outputs of detectors are compared by the comparator is used, then the output of comparator is the bit sequence $b(t)$.

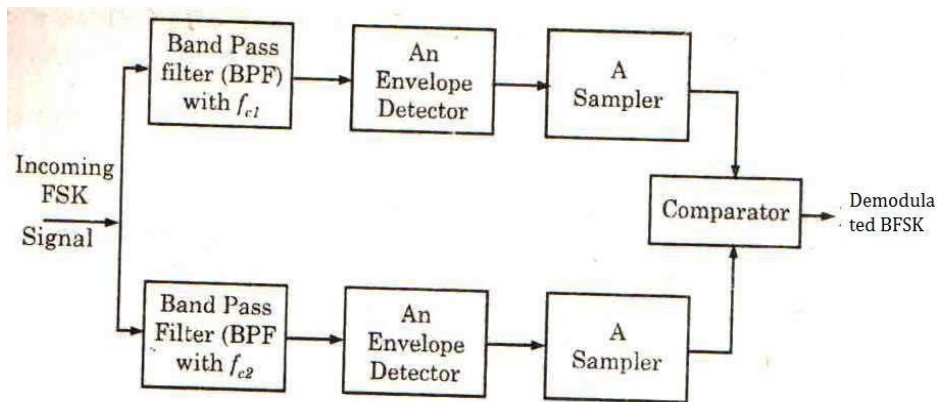

Fig . Demodulation of BFSK Signal

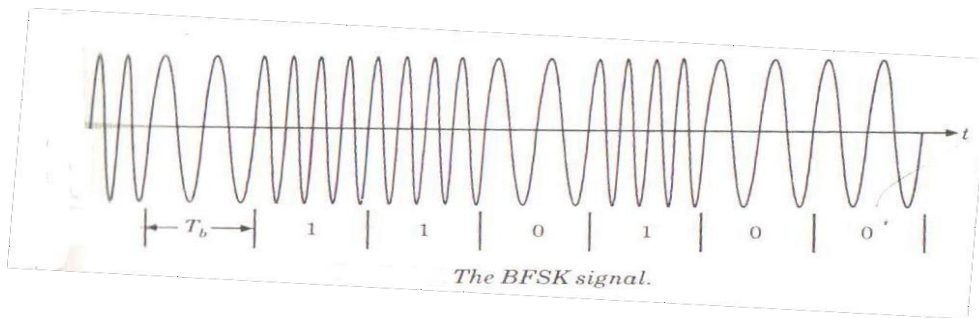

Fig. Waveform of BFSK Signal

GENERATION AND DETECTION OF BPSK-

BINARY PHASE SHIFT KEYING (BPSK):-

In binary phase shift keying, binary symbol '1' and '0' modulate the phase of the carrier. Let us assume that the carrier is given as,

$$S(t) = A \cos(2\pi f_c t)$$

Here 'A' represents peak value of sinusoidal carrier. The power dissipated would be

$$P = \frac{1}{2} A^2$$

$$A = \sqrt{2P}$$

For symbol '1'

$$S_1(t) = \sqrt{2P} \cos(2\pi f_c t)$$

If next symbol is '0', then we have, for

symbol '0'

$$S_2(t) = \sqrt{2P} \cos(2\pi f_c t)$$

Because $\cos(\theta + \pi) = -\cos \theta$, therefore the above equation can be written as, $S_2(t) =$

$$-\sqrt{2P} \cos(2\pi f_c t)$$

We can define BPSK signal combinely as,

$$S(t) = b(t) \sqrt{2P} \cos(2\pi f_c t)$$

$b(t) = +1$ when binary '1' is to be transmitted

-1 when binary '0' is to be transmitted

GENERATION OF BPSK SIGNAL :-

The BPSK signal may be generated by applying carrier signal to a balanced modulator. Here, the baseband signal $b(t)$ is applied as a modulating signal to the balanced modulator.

A NRZ level encoder converts the binary data sequence into bipolar NRZ signal.

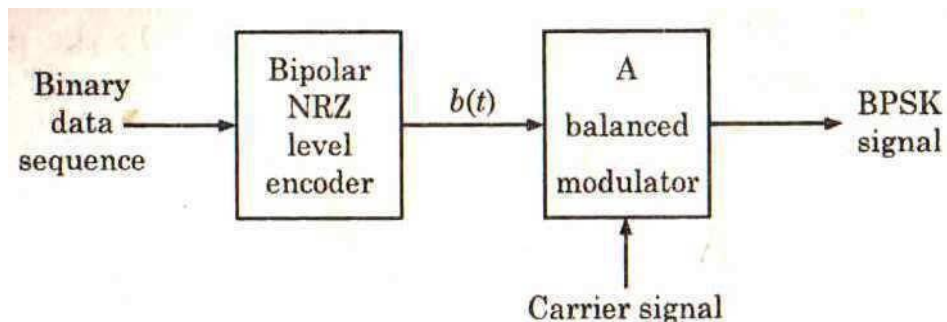
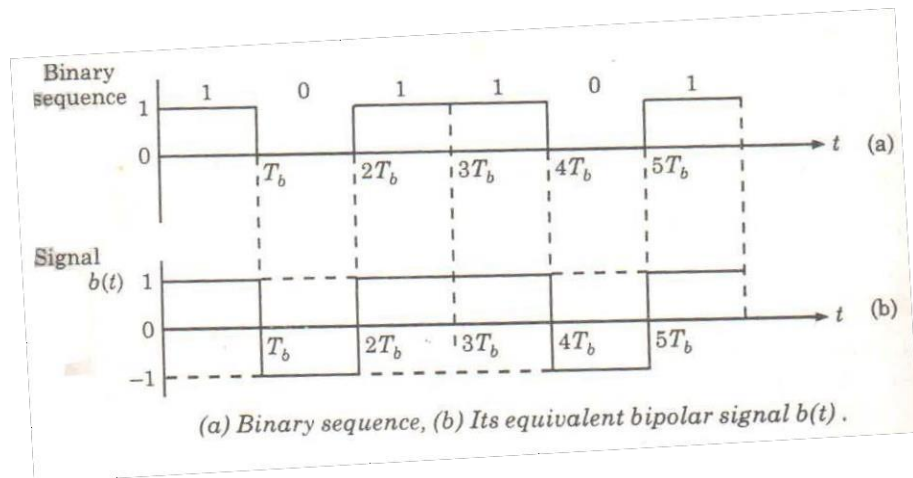

Fig. Generation of BPSK



DEMODULATION OF BPSK :-

The transmitted BPSK signal is given as

$$S(t) = b(t) \sqrt{2P} \cos(2\pi f_c t)$$

This signal undergoes the phase change depending upon the time delay from transmitter end to receiver end. This phase change is usually a fixed phase shift in the transmitted signal.

Let this phase shift be θ . Therefore, the signal at the input of the receiver can be written as

$$S(t) = b(t) \sqrt{2P} \cos(2\pi f_c t + \theta)$$

Now, from this received signal, a carrier is separated because this is coherent detection. The received signal is allowed to pass through a square law device, we get a signal which is given as,

$$\cos^2(2\pi f_c t + \theta)$$

Again, we know that

$$\cos^2 \theta = (1 + \cos 2\theta) / 2$$

Therefore, we have

$$\begin{aligned} \cos^2(2\pi f_c t + \theta) &= (1 + \cos 2(2\pi f_c t + \theta)) / 2 \\ &= \frac{1}{2} + \frac{1}{2}(\cos 2(2\pi f_c t + \theta)) \end{aligned}$$

Here, $\frac{1}{2}$ represents a DC level. This signal is then allowed to pass through a band pass filter whose pass band is centered around $2f_c$. Band pass filter removes the DC level of $\frac{1}{2}$ and at the output, we obtain

$$\cos 2(2\pi f_c t + \theta)$$

Then this signal is passed through a frequency divider by two. Thus, at the output of frequency divider we get a carrier signal whose frequency is f_c i.e.,

$$\cos(2\pi f_c t + \theta)$$

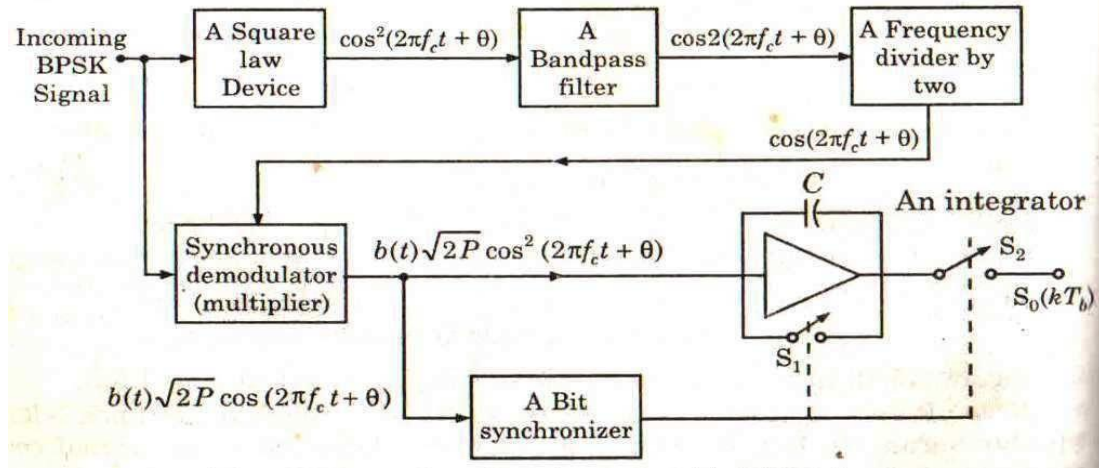

Fig. Reception of Baseband Signal in BPSK

The synchronous demodulator multiplies the input signal. The output of multiplier is,

$$\begin{aligned} b(t) \sqrt{2P} \cos(2\pi f_c t + \theta) \times \cos(2\pi f_c t + \theta) &= b(t) \sqrt{2P} \cos^2(2\pi f_c t + \theta) \\ &= b(t) \sqrt{2P} \times \frac{1}{2} [1 + \cos 2(2\pi f_c t + \theta)] \\ &= b(t) \sqrt{P/2} [1 + \cos 2(2\pi f_c t + \theta)] \end{aligned}$$

This signal is then applied to the bit synchronizer and integrator. The integrator integrates the signal over one bit period. The bit synchronizer takes care of starting and ending times of a bit. At the end of bit duration T_b , the bit synchronizer closes switch S_2 temporarily. This connects the output of an integrator to the decision device. The synchronizer then opens switch S_2 and switch S_1 is closed temporarily. The integrator then integrates next bit. This signal is then applied to a decision device which decides whether transmitted symbol was zero or one.

BANDWIDTH

The minimum bandwidth of BPSK signal is equal to twice of the highest frequency contained in baseband signal. $BW = 2f_b$

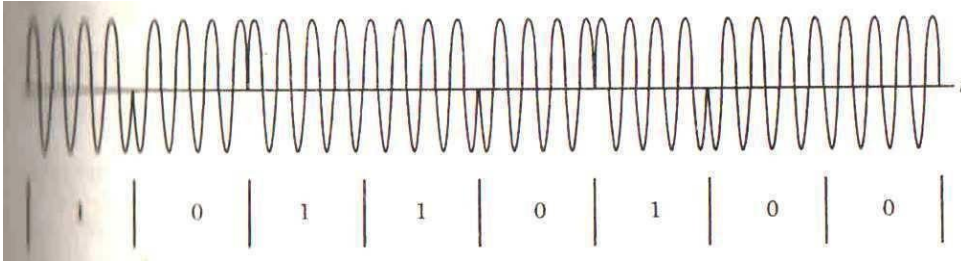

Fig. Waveform generation Baseband Signal in BPSK

GENERATION AND DETECTION OF DPSK-

Differential phase shift keying (DPSK)

The differential phase shift keying is the non-coherent version of the PSK. DPSK does not need a synchronous carrier at the demodulator

Generation of DPSK

The digital information content of the binary data is encoded in terms of signal transitions. As an example, the symbol '0' may be used to represent transition in a given binary sequence and symbol '1' indicate no transition. This new signaling technique that combines differential encoding with phase shift keying is known as differential phase shift keying.

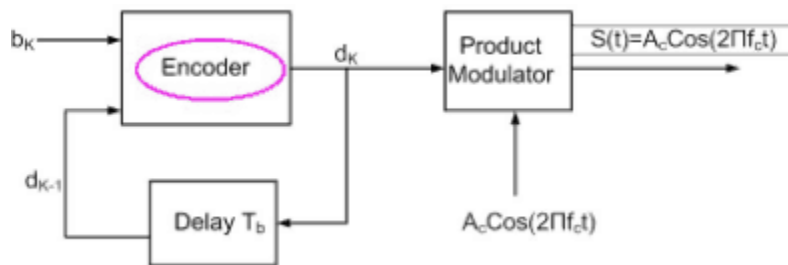

Fig. Illustration of The Scheme for the generation of DPSK Signal

The data stream $b(t)$ is applied to input of the encoder. To another input of the encoder delayed version of the encoder output is applied. The output of the encoder is applied to one input of the product modulator. To the other input of this product modulator a sinusoidal carrier of fixed amplitude and frequency is applied.

Detection DPSK-

The received DPSK signal is applied to one input of the multiplier. To the other of the multiplier, a delayed version of the received DPSK signal by the time interval T_b is applied. The output of the difference is proportional to $\cos(\phi)$, where ϕ is the difference between the carrier phase angle of the received DPSK signal

and its delayed version, measured in the same bit interval. The phase difference between the two sequences for each bit interval is used to determine the sign of the phase comparator output. When $\phi=0$, the integrator output is positive whereas when $\phi=\pi$, the integrator output is negative. By comparing the integrator output with a decision level of zero volt, the decision device can reconstruct the binary sequence by assigning a symbol 0 for negative output and symbol 1 for positive output. In the absence of noise the receiver can reconstruct the transmitted binary data exactly.

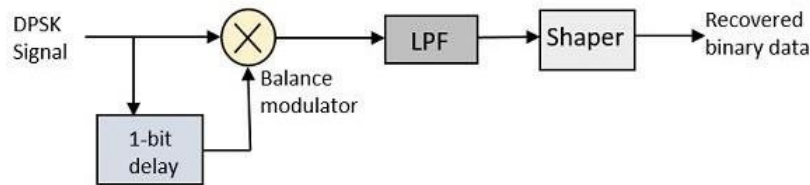

Fig. Receiver for the detection of DPSK signals

Advantages:-

DPSK does not need carrier at the receiver end. This means that the complicated circuitry for generation of local carrier is not required. The bandwidth requirement of DPSK is reduced as compared to that of BPSK.

QPSK-

In communication systems, we have two main resources. These are the transmission power and the channel bandwidth. The channel bandwidth depends upon the bit rate or signalling rate f_b . If two or more bits are combined in some symbols, then the signalling rate will be reduced. This reduces the transmission channel bandwidth.

In quadrature phase shift keying, two successive bits in the data sequence are grouped together. This reduces the bits rate or signaling rate and thus reduces the bandwidth of the channel.

In case of BPSK, when symbol changes the level, the phase of the carrier is changed by 180. Because, there were only two symbols in BPSK, the phase shift occurs in two levels only. However, in QPSK, two successive bits are combined. This combination of two bits forms four distinct symbols. When the symbol is changed to next symbol, then phase of the carrier is changed by 45.

GENERATION OF QPSK TRANSMITTER-

The toggle flip-flop is driven by a clock waveform whose period is the bit time T_b . The toggle flip-flop generates an odd clock waveform and an even waveform. The active edge of one of the clock and the active edge of the other are separated by the bit time T_b . The bit stream $b(t)$ is applied as the data input to both type-D flip-flops, one driven by the odd and one driven by the even clock waveform.

The output bit stream $b_e(t)$ is superimposed on a carrier $\sqrt{P_s} \cos \omega_c t$ and the bit stream $b_o(t)$ is superimposed on a carrier $\sqrt{P_s} \sin \omega_c t$ by the use of two multipliers to generate two signals $S_e(t)$ and $S_o(t)$. These signals are then added to generate the transmitted output signal $S(t)$ which is

$$S(t) = \sqrt{P_s} b_o(t) \sin \omega_c t + \sqrt{P_s} b_e(t) \cos \omega_c t$$

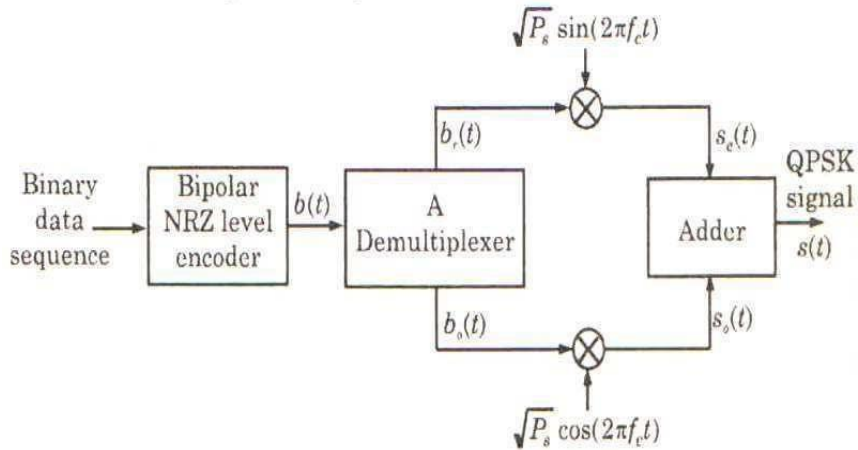

Fig. Generation of QPSK Signal

DETECTION OF QPSK-

The incoming signal be raised to the fourth power after which filtering recovers a waveform at four times the carrier frequency and finally frequency division by four regenerates the carrier.

The incoming signal is also applied to two synchronous demodulators consisting of a multiplier followed by an integrator. The integrator integrates over a two bit interval of duration $T_s=2T_b$. One demodulator uses the carrier $\cos \omega_c t$ and the other one uses the carrier $\sin \omega_c t$. The integrator output is sampled. Samples are taken alternatively from one and other integrator output at the end of each bit time T_b and these samples are held in the latch for the bit time T_b . Each individual integrator output is sampled at intervals $2T_b$. The latch output is the recovered bit stream $b(t)$.

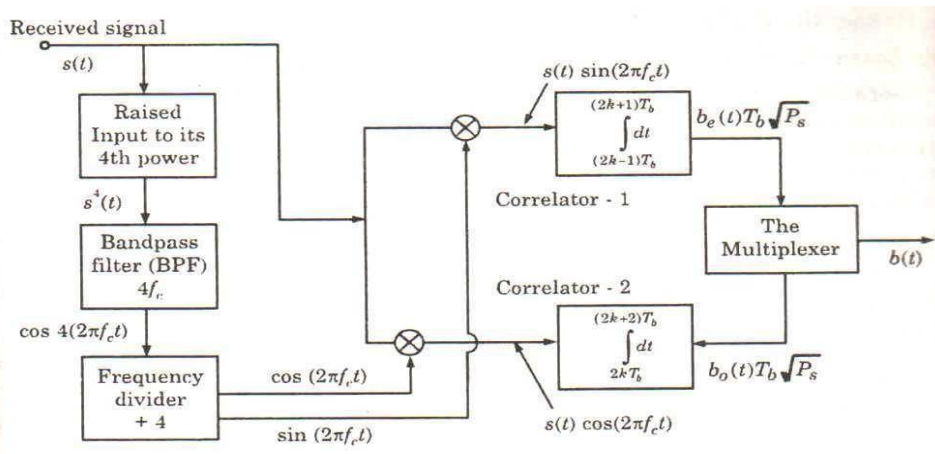

Fig. Reception of QPSK Signal

Advantages:

1. For the same bit error rate, the bandwidth required by QPSK is reduced to half of compared to BPSK.
2. Because of reduced bandwidth the information transmission rate of QPSK is higher.
3. Variation in QPSK amplitude is not much. Hence carrier power almost remain constant.

SPREAD SPECTRUM

What is Spread Spectrum?

The increasing demand for wireless communications has problems due to limited spectrum efficiency and multipath propagation. The use of spread spectrum communication has simplified these problems. In the spread spectrum, signals from different sources are combined to fit into **larger bandwidth**.

Most stations use air as the medium for communication, stations must be able to share the medium without an interception and without being subject to jamming from a malicious intruder. To achieve this, spread-spectrum techniques add redundancy means it uses **extended bandwidth** to accommodate signals in a protective envelope so that more secure transmission is possible. The spread code is a series of numbers that looks random but are actually a pattern. The original bandwidth of the signal gets **enlarged** (spread) through the spread code as shown in the figure.

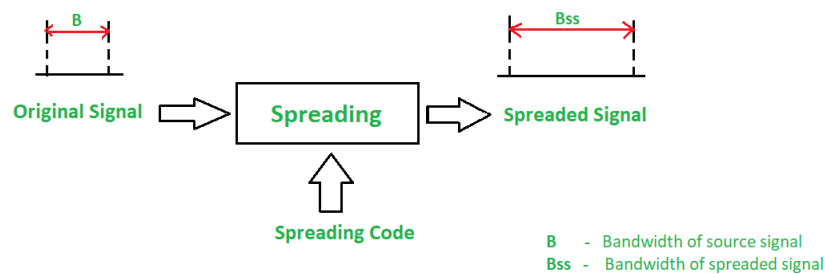

Principles of Spread Spectrum process:

1. To allow redundancy, it is necessary that the bandwidth allocated to each station should be much larger than needed.
2. The spreading process occurs after the signal is created by the source.

Conditions of Spread Spectrum are:

1. The spread spectrum is a type of modulation where modulated signal BW is much larger than the baseband signal BW i.e. spread spectrum is a wide band scheme.
2. A special code (pseudo noise) is used for spectrum spreading and the same code is to be used to despread the signal at the receiver.

Characteristics of the Spread Spectrum are:

Higher channel capacity.

Ability to resist multipath propagation.

They cannot easily intercept any unauthorized person.

They are resistant to jamming.

The spread spectrum provides immunity to distortion due to multipath propagation.

The spread spectrum offers multiple access capabilities.

Two types of techniques for Spread Spectrum are:

Frequency Hopping Spread Spectrum (FHSS)

Direct Sequence Spread Spectrum (DSSS)

Frequency Hopping Spread Spectrum (FHSS):

In Frequency Hopping Spread Spectrum (FHSS), different carrier frequencies are modulated by the source signal i.e. M carrier frequencies are modulated by the signal. At one moment signal modulates one carrier frequency and at the subsequent moments, it modulates other carrier frequencies. The general block diagram of FHSS is shown in the below figure.

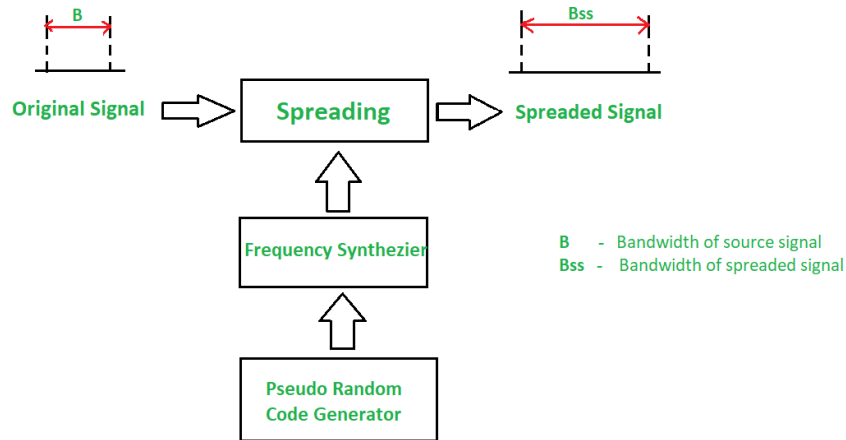

A pseudorandom code generator generates Pseudo-random Noise of some pattern for each hopping period T_h . The frequency corresponding to the pattern is used for the hopping period and is passed to the frequency synthesizer. The synthesizer generates a carrier signal of that frequency. The figure above shows the spread signal via FHSS.

Advantages of FHSS:

- Synchronization is not greatly dependent on distance.
- Processing Gain is higher than DSSS.

Disadvantages of FHSS:

- The bandwidth of the FHSS system is too large (in GHz).
- Complex and expensive Digital frequency synthesizers are required.

Direct Sequence Spread Spectrum (DSSS):

In DSSS, the bandwidth of the original signal is also expanded by a different technique. Here, each data bit is replaced with n bits using a spreading code called **chips**, and the bit rate of the chip is called as **chip-rate**. The chip rate is n times the bit rate of the original signal. The below Figure shows the DSSS block diagram.

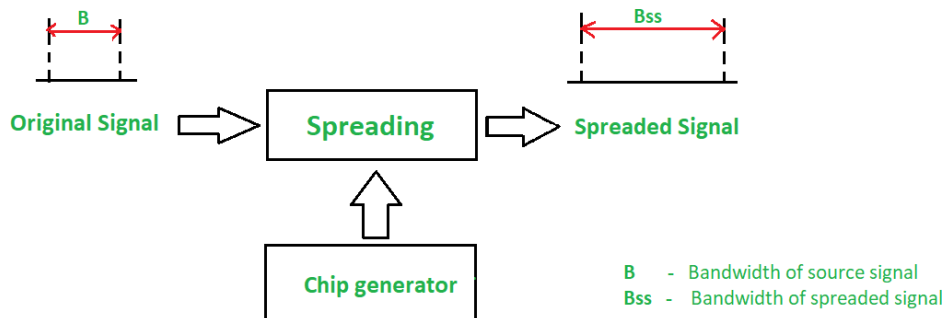

In wireless LAN, the sequence with $n = 11$ is used. The original data is multiplied by chips (spreading code) to get the spread signal. The required bandwidth of the spread signal is 11 times larger than the bandwidth of the original signal.

Advantages of DSSS:

- The DSSS System combats the jamming most effectively.
- The performance of DSSS in presence of noise is superior to FHSS.
- Interference is minimized against the signals.

Disadvantages of DSSS:

- Processing Gain is lower than DSSS.
- Channel Bandwidth is less than FHSS.
- Synchronization is affected by the variable distance between the transmitter and receiver.

SHANNON THEOREM:

Shannon showed that error-free communication is possible on a noisy channel provided that the data rate is less than the channel capacity. Shannon capacity (data rate) equation is the basis for spread spectrum systems, which typically operate at a very low SNR, but use a very large bandwidth in order to provide an acceptable data rate per user.

CHANNEL CAPACITY “C”:

Channel capacity —C (error free bps) is directly proportional to the bandwidth —B and is Proportional to the log of SNR.

$$C = B \times \log_2(1+S/N)$$

Where

C is the channel capacity in bits per second (bps), which is the maximum data rate for a theoretical bit error rate (BER)

B is the required bandwidth in Hz

S/N is the signal to noise ratio

[Note: C which represents the amount of information allowed by communication channel, also represent the desired performance. S/N ratio expresses the environmental conditions such as obstacles, presence of Jammers, interferences, etc.]

In Shannon formula by changing the log base from 2 to e (the Napierian number) and noting that $e \ln = \log$ Therefore:

$$C/B = (1 / \ln 2) \times \ln(1 + S/N) = 1.443 \times \ln(1 + S/N)$$

BAUD:-In telecommunication and electronics, **baud** (unit symbol Bd) is the unit for symbol rate or modulation rate in symbols per second or pulses per second. It is the number of distinct symbol changes (signaling events) made to the transmission medium per second in a digitally modulated signal or a line code.

BIT: - A **bit** is the basic unit of information in computing and digital communication. A bit can have only one of two values, and may therefore be physically implemented with a two-state device. These values are most commonly represented as either a 0 or 1. The term *bit* is a called of **binary digit**.

SYMBOL:-A **symbol** is an object that represents, stands for, or suggests an idea, visual image, belief, action, or material entity. Symbols take the form of words, sounds, gestures, or visual images and are used to convey ideas and beliefs

MODEM

Modem:-

Modem is a contraction of the term Modulator & Demodulator. Both functions are included in modem. When used in the transmitting mode, the modem accepts digital data and converts it to analog signals for use in modulating a carrier signal. At the receive end of the system, the carrier is demodulated to recover the data.

There are two types of MODEM,

1. The Hard-wired Modem
2. The acoustically coupled data set.

THE HARD-WIRED MODEM:

The Hard-wired Modem connects directly to the communication circuit in semi-permanent way. Such modems may be self-contained devices which connect to terminals and business machines, or they may be incorporated in the business machines.

The one limitation of the Hard-wired Modem is that it precludes mobility since, being hard-wired, the equipment must remain connected to the circuit terminals.

THE ACOUSTICALLY COUPLED DATA SET:

The acoustically coupled data set modem solves the mobility problem. A standard telephone handset can be placed in the foam cups of an acoustic coupler, and the transmitter and receiver sounds will be conveyed to and from the telephone channel by transmit and receive elements of the acoustic coupler. The modem components of the acoustic coupler form an interface with the business machine.

Reference Books:

1. Communication Systems (Analog & Digital) by Sanjay Sharma-KATSON
2. Communication System by V. Chandrasekhar-OXFORD Publication
3. Principle of Communication by Lovis E. Frenzel.-TMG
4. Advanced Communication by Thomasi.-PHI
5. Electronics Communication by G. Kennedy- MGH

